



 Logoplaste

SUSTAINABILITY REPORT 2023

CONTENTS

AT A GLANCE	6	INNOVATION	75
Who are we? 7			
Sustainability 12			
THE ENVIRONMENT	15	RECOGNITION	81
Positive Impact 16			
Energy 17			
Greenhouse Gas Emissions 22			
Materials & Product Characteristics 29			
Circularity 30			
Water 32			
Waste 34			
SAFETY	36	MORE ...	84
Non-negotiable 37		Report profile 85	
OHS Metrics 41		Sustainability Governance 86	
		Materiality Assessment 88	
		Stakeholder engagement 90	
		Sustainable Development Goals (SDGs) 92	
		Certifications and memberships 95	
		GRI Content Index 97	
PEOPLE	47	APPENDICES	109
Engagement 48		Appendix 01 110	
HR metrics 54		Appendix 02 113	
Ethics & Integrity 71		Appendix 03 115	
		Appendix 04 117	
		Appendix 05 120	



Welcome to our GRI Sustainability Report 2023.

We hope you find the report useful, but first a message
from our Chairman and our CEO.



“Since the very beginning in 1976, Logoplaste has had a clear strategy of embedding its plants inside its partners’ operations, creating endless ways to reduce waste, save time, and improve quality.

Sustainability at Logoplaste has always been bigger than our embedded, wall to wall model. We pioneered plastic recovery, recycling, and conversion and have always worked to create a better and more sustainable world.

My father dedicated his life to Logoplaste, rigid plastic packaging, and recycling. From the 1990s to his passing in 2022,

he worked to transform plastic packaging into a sustainable industry.

To honor his memory, we established the Marcel de Botton Sustainability Awards to recognize plants that excel in managing resources, minimizing waste, and ensuring the health and safety of everyone who enters any of our facilities, anywhere in the world.

Now in its second year, the awards recognized two plants for their outstanding efforts:

Logoplaste Mealhada won the Performance Award for best overall results.

Logoplaste Elst obtained the Commitment Award for the greatest improvement year over year.

In addition to the recognition, Logoplaste provides each winner with 25.000€ to be donated to a local charity of their choice.

While Mealhada and Elst led our efforts in 2023, our Sustainability Report shows that our commitment to a more sustainable future is global.

I would like to thank all the “Logoplastians” worldwide for the amazing work delivered at our 67 plants, and offices.

Nothing would be possible without your constant commitment in making the world a better place.”

Filipe de Botton
Chairman



“Logoplaste’s GRI Sustainability Report shows how we are living our values and truly “walking our talk.”

The report gives us objective KPIs of our progress in transforming plastic packaging manufacturing into an industry that supports a circular, bottle-to-bottle, economy.

One of the most critical sustainability issues for Logoplaste, and the planet, is climate change.

Logoplaste collaborates with the Science Based Target Initiative (SBTi) to set targets for reducing our CO2 emissions by

increasing our energy efficiency, our use of renewable energy, and the amount of recycled content in our products.

As you’ll see in the report, we’ve set ambitious goals across the board, which we are meeting or exceeding. I’m incredibly proud to tell you that Ecovadis—the world’s largest provider of business sustainability ratings—ranks Logoplaste in the top 2% of plastic packaging manufacturers and the top 5% of all participating companies in the world.

Sustainability is not just about the environment. It includes how we interact with our suppliers and partners, and how we care for our people and the communities in which we operate.

As you review the 2023 Sustainability Report, you’ll find that we do indeed live our values, and fulfill our purpose. Results like these are what happens when amazing people, at every level of Logoplaste, work together to build a better future every single day of the year.

Thank you all—our employees, partners, and suppliers—for making 2023 the most sustainable year in our history... for now. We expect 2024 to be even better.

I hope you enjoy reading our report and learning more about who we are and how we operate. I think you’ll find we are all about exceeding expectations and pushing boundaries.”

Gerardo Chiaia
CEO



AT A GLANCE



WHO ARE WE?

Logoplaste works to create a circular economy for plastic packaging

Our goal: 100% bottle-to-bottle lifecycle that reuse and recycle plastic in an endless, efficient loop.

Skeptical? We understand, but creating sustainable plastic packaging is much more than our duty. It's our only viable future.

We are putting all of our skill, knowledge, and creativity to work to make it happen.

We're the company who invented the wall to wall, embedded manufacturing, and now we're leading the way to sustainable plastic packaging.

Logoplaste designs and manufactures innovative packaging that jumps off the shelf. We do it using the most sustainable processes and materials.

Our purpose is to relentlessly push boundaries, to go beyond our clients' expectations, and to transform rigid plastic packaging's impact on the planet by reducing CO₂ emissions along the entire value chain.

Every day, we push against the norm and question what's been done before so that we can lead the changes our industry must make.

We're dedicated to working together - with our clients and our competitors, our local communities and governments - to build a better, healthier, sustainable future for the next generation.

This legacy is more than words on a page. It is our duty.

■ WHO ARE WE?



OUR VOICE

Honest, transparent, smart, friendly.



OUR PROMISE

Deliver quality packaging that has a positive impact on the environment and society.



OUR VALUES

Dedication, sustainability, integrity, quality.



OUR ESSENCE

Exceed customer expectations, without losing focus on sustainability.



OUR PERSONALITY

Visionary, resourceful, non-conformist, clever, truthful, charismatic, human.



OUR PURPOSE

To shape a better world with our partners through mindful packaging solutions.



OUR POSITIONING

Be the most sustainable and reliable supplier for rigid plastic packaging.



OUR TRUTH

Report data following the highest standards, leaving no room for doubt.



OUR N°1 GOAL

Taking care of our team.

Wall to wall manufacturing



Smaller footprint, less CO₂



1/1/1 focus



Lower costs, higher efficiency



Lower stocks of finished product



No secondary packaging



No freight, no empty bottle transportation

Reduce CO₂ emissions at every stage with wall to wall manufacturing

When it comes to sustainability, what people really want to know is what you are doing right now. Shifting from remote packaging production to embedded, wall to wall manufacturing with Logoplaste makes an immediate impact on your carbon footprint and your bottom line.

WHO ARE WE?

Logoplaste's 2023 KPIs

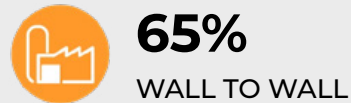
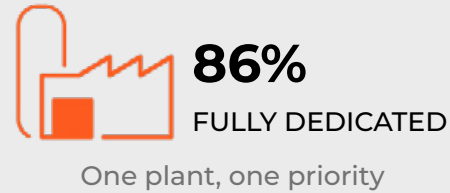
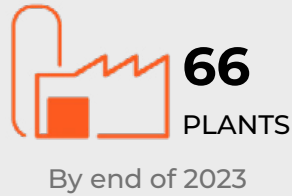

Market segments

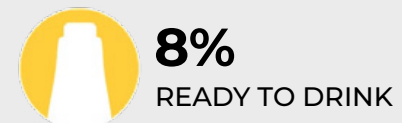
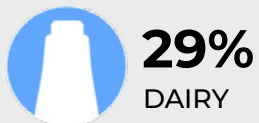

WHO ARE WE?

Logoplaste team



2692
EMPLOYEES



11
OFFICIAL
LANGUAGES



42
AVERAGE
AGE



7
YEARS OF
SERVICE



76% vs 23%
MEN VS WOMEN

Keeping score



12
GLOBAL
INDUSTRIAL
KPIs REPORTS



12
QUALITY
METRICS
REPORTS



12
GLOBAL
EHS
REPORTS



12
GLOBAL
HR
REPORTS



19 941
PROACTIVE
ACTIONS

■ SUSTAINABILITY

For Logoplaste, sustainability and mindful plastic packaging are one and the same.

Why? Because all the packaging we produce has environmental and social consequences.

Delivering bottles is a big responsibility, and we take their entire lifecycle into consideration, from design to engineering & manufacture, to recycling performance & certifications.

We think through every stage of a bottle's life, from the moment a brand manager dreams it up to the day it is broken-down and transformed into a new bottle.



3 Pillars for Sustainability

Transforming the present and creating a sustainable future depends on getting these fundamentals right.



PEOPLE & COMMUNITY

We build workplaces and communities that help everyone reach their potential are essential.



ENVIRONMENT & ECONOMY

We create healthy, equitable economies that care for the environment.



INNOVATION

We invent, imagine, and invest in new ways of working.

■ SUSTAINABILITY

Keeping score and keeping track

We are not alone, and this is a good thing. It helps us on our path to align with our industry peers, clients, and other business partners. To do this in an organized and consistent manner, Logoplaste participates in benchmarks and engages with world class organizations.



ecovadis



United Nations
Global Compact

We are as hard on ourselves, as on others. Keeping a firm line is the only way to see positive results.

■ SUSTAINABILITY

We have set our objectives:

Reduce by 30% our Operational* CO₂e emissions and our CO₂e intensity indicator by 2030**

This ambitious target's base year is 2019, and we aim to reach this reduction by acting on two fronts. For plants where we control the energy supply, we will have specific plans in place for each site. For embedded, wall-to-wall operations, where we do not control the energy supply, we will work closely with our customers to reach our targets.

* Scope 1 and 2 ** Intensity of CO₂e emissions relative to production

Our commitments for 2025 follow the New Plastics Economy Global Commitment led by the Ellen MacArthur Foundation



- Eliminate unnecessary plastic packaging
- Where possible, move from single use toward reuse models
- 100% of plastic packaging to be reusable or recyclable
- Continue increasing the use of recycled content across all packaging and exceed the legal requirements for the use of PCR



THE ENVIRONMENT

POSITIVE IMPACT

Our embedded manufacturing business model, aka wall to wall, allows us to reduce the use of resources, minimizing our impact on the environment as well as support local communities in which we operate.

Logoplaste's approach to Environmental Management follows the Precautionary Principle, as defined in the United Nations Rio Declaration, 1992. We have a global **Quality, Environment, Health & Safety (QEHS) Policy**, overseen by our Corporate Environmental Health & Safety (EHS) Team, stating our guiding principles and commitments towards the environment.

OUR PURPOSE

“Shaping a better world with our Partners through mindful packaging solutions.”

Guides our efforts, every single day.

Energy



24%

INCREASE IN RENEWABLE
ELECTRICITY FROM 2022

GHG emissions



15%

REDUCTION OF
OPERATIONAL CO₂E
EMISSIONS FROM 2019

Materials & Product characteristics



22%

INCORPORATION OF
RECYCLED CONTENT

Water



20%

REDUCTION ON WATER
WITHDRAWAL FROM HIGH
WATER STRESS AREAS
FROM 2022

Waste



98%

OF OPERATIONAL WASTE
SENT FOR RECYCLING OR
REUSE

ENERGY

The production of plastic packaging is energy intensive, therefore we continually track the energy consumption of our plants and offices.

In 2023, Logoplaste’s overall energy consumption was **1 518 811 GJ**, **4%** more energy than in 2022. This is mainly due to the ramping-up of some sites.

Our total energy consumption in 2023

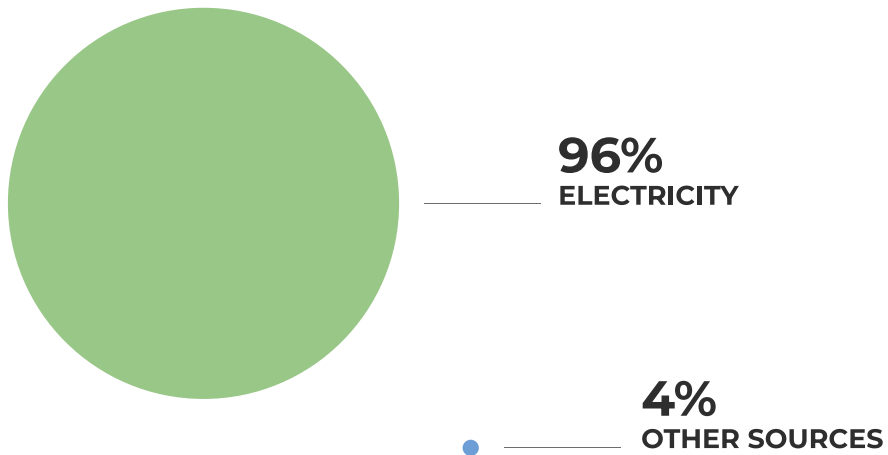

Overview of Energy Consumption within Logoplaste

Energy Consumption			
Year	Electricity (GJ)	Fuel - Non-renewable sources (GJ)	Total (GJ)
2019	1 161 698 (97%)	40 119 (3%)	1 201 817
2020	1 333 762 (97%)	45 764 (3%)	1 379 526
2021	1 302 733 (97%)	43 392 (3%)	1 346 125
2022	1 392 231 (96%)	62 333 (4%)	1 454 568
2023	1 453 419 (96%)	65 391 (4%)	1 518 811
2023 vs 2022 (%)	4%	5%	4%
2023 vs 2019 (%)	25%	63%	26%

ENERGY

In 2023, electricity continues to be the most significant form of energy we use, with **88%** sourced from the electrical grid.



Overview of Electricity Consumption within Logoplaste

		Electricity Consumption			
		Grid - brown electricity	Grid - 100% green electricity	CHP* systems (natural gas)	Photovoltaic panels
2019	Energy (GJ)	978 185	78 680	103 123	1 711
	%	84.2%	6.8%	8.9%	0.1%
2020	Energy (GJ)	1 100 925	127 148	101 766	3 923
	%	82.5%	9.6%	7.6%	0.3%
2021	Energy (GJ)	918 875	276 787	102 762	4 308
	%	70.5%	21.3%	7.9%	0.3%
2022	Energy (GJ)	873 902	403 999	107 729	6 601
	%	62.8%	29.0%	7.7%	0.5%
2023	Energy (GJ)	832 692	499 013	112 099	9 615
	%	57.3%	34.3%	7.7%	0.7%
2023 vs 2022 (%)		-4.7%	23.5%	4.1%	45.7%
2023 vs 2019 (%)		-14.9%	534.2%	8.7%	462.0%

* Combined Heat and Power

ENERGY

Using energy more efficiently and opting for renewable energy sources across our operations is essential to improve our environmental footprint and accomplish Logoplaste’s operational emissions reduction target. At Logoplaste, we are taking big steps to move to green energy across the board.

Overview of renewable electricity consumption

Renewable Electricity Consumption		
Year	Energy (GJ)	YoY* (%)
2019	80 391	-
2020	131 072	63.0%
2021	281 096	114.5%
2022	410 600	46.1%
2023	508 628	23.9%
2023 vs 2019 (%)		532.7%

*YoY - year on year improvement

In 2023, we used **508 628 GJ** of renewable electricity, which represented **35%** of our electricity consumption, and **34%** of our total energy consumption.

This represents a 24% increase from 2022 and a 533% from base year 2019.

Having a sustainable mindset and leading a sustainable business means making decisions that allowed us to reach these impressive results. It’s not always easy and can carry added financial costs, but for us, at Logoplaste, it is the only way to go.

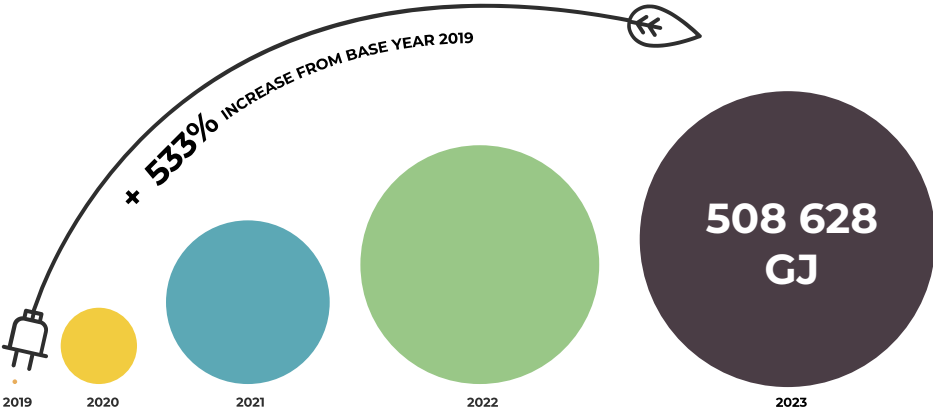

i Detailed energy consumption and the methodological process we use to analyze data can be consulted in Appendix 01.

ENERGY

Energy reduction activities

We continually strive to improve our energy efficiency and energy best practices, as it helps protect the environment, while reducing costs. To help us to this, we have a dedicated team for Energy Management across the globe.

In the past years, Logoplaste implemented several energy-reduction activities and best practices, including machine and utilities optimization; HVAC and equipment upgrades or replacements; automation; smart devices; lightning efficiency; energy audits; and general energy rationalization with daily management, such as switching off unused equipment.

Compliance with maintenance plans and employee environmental awareness are fundamental for our energy efficiency path.

Keeping a sharp eye on energy and making mature, conscious decisions.

Giovanni Della Greca, Plant Manager at Pomezia – Italy, shares how energy is managed and optimized:

“Energy efficiency is a parameter that we monitor very closely in Pomezia. Over the past years we have learnt that the key in obtaining good, as well as sustainable results, is to have a clear picture of the energy consumption components. Hence, investments have been made to install meters that monitor energy consumption from every single equipment and machine, giving us precise information.

This is the initial stage of the analysis, where the data gives us an undisputed overview of our consumption patterns, helping to define strategies and set priorities. Once improvements measures have been put into place, we look at the readings again to verify the results of the actions in place.

WE FOCUS ON 3 MAIN AREAS TO KEEP ENERGY CONSUMPTION CONTROLLED:

INVESTMENTS

Any manufacturing plant has needs and opportunities that require investments.

They may not be specifically oriented to energy efficiency but can be related to business expansion or equipment replacement. Whatever the investment, you always need to look at the impact on energy efficiency, as if it has a negative impact, the investment payback will be higher. The renewal of energy-intensive equipment has become part of the decision-making process at Pomezia.

ENERGY

SMALL PROJECTS

This is probably the most important area of intervention. Small Projects are all the initiatives that do not have a huge cost and can be managed autonomously by the plant.

We have both improvements on production and ancillary machines, as well as energy saving activities all around the building (led lamps, light sensors,...).

They are key to the plant, not just bringing a contribution to the energy consumption reduction but also communicating and reinforcing an Energy Saving Culture. In fact, a daily focus and commitment from the entire team is crucial for the success of the initiatives; it is essential to find time to discuss these matters, define responsibilities and timelines.

OPTIMIZED OPERATION PLANNING

When we plan the production, the main goal is to fully cover the customer's needs. But we can do this and, at the same time, try to optimize the energy consumption, especially that of the auxiliary systems, as they are designed to serve several machines at the same time. The objective is to have a higher number of machines in operation so that we optimize the usage of auxiliary systems.

This is not easy, and sometimes not viable; however it demonstrates Pomezia's commitment to optimizing energy consumption.



Giovanni Della Greca
Plant Manager
Pomezia, Italy

GREENHOUSE GAS EMISSIONS

Our business model reduces GHG by default

Our embedded manufacturing plants as well as nearby sites, lower CO₂ emissions by eliminating, or reducing, the transport of empty bottles.

By operating 86% of our sites within our customers' premises or near them, in 2023 Logoplaste avoided the release of 15 267 tons of CO₂, a 2% increase compared to 2022 (15 005 tons CO₂).

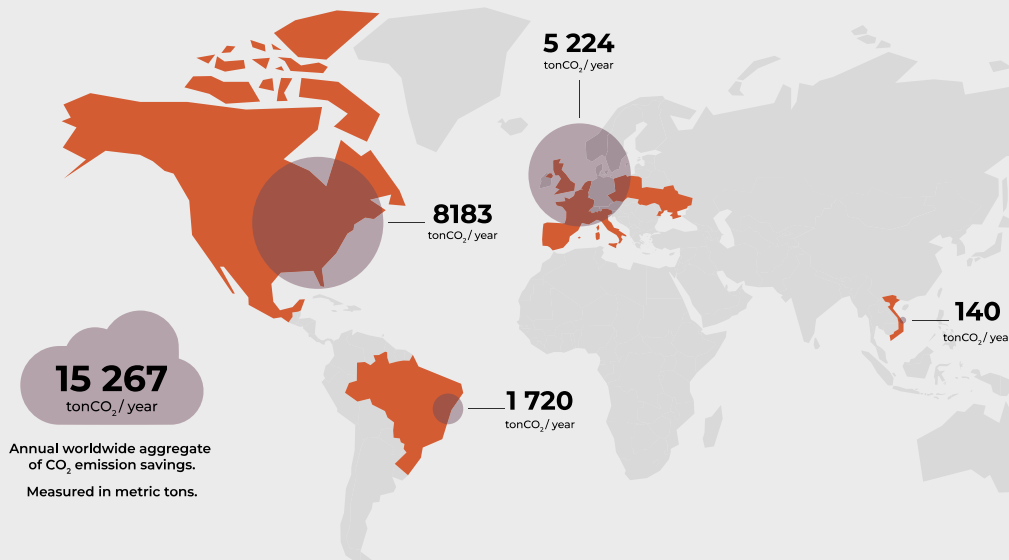

In June 2022 Logoplaste signed the **SBTi (Science Based Target Initiative)** commitment letter to:

- Set science-based emissions reduction targets (near-term targets) by 2030
- Set net-zero targets, including a long-term science-based targets by no later than 2050, in line with the SBTi Net-Zero Standard

And we are very proud to announce that we submitted our science-based targets for SBTi approval by the end of 2023.

To enhance the credibility and accuracy of our data, our carbon footprint information, covering Scope 1, 2, and 3 emissions for the period ending December 31, 2023, has been audited by PwC through a limited assurance engagement.



Details of the independent limited assurance report confirming the audit can be consulted in Appendix 05.

GREENHOUSE GAS EMISSIONS

Scope 1 and Scope 2 greenhouse gas emissions

Logoplaste's operational GHG emissions

SCOPE 1 GHG EMISSIONS are direct emissions from the use of fossil fuels within Logoplaste, plus fugitive emissions (resulting from refrigerant gases leaks).

SCOPE 2 GHG EMISSIONS are indirect emissions from the purchase of electricity for Logoplaste sites and offices.

Absolute Emissions

In 2023, the total of Scope 1 & 2 (market-based) emissions – **Logoplaste's operational CO₂e Emissions** - was **89 060 tons of CO₂e**. This represents a decrease of **5%** compared to 2022. And a **15% reduction in Operational GHG emissions** when compared to base year, 2019.

Logoplaste's operational GHG emissions (Scope 1 and Scope 2 market-based)

	2019		2020		2021		2022		2023		2023 vs 2022 (%)	2023 vs 2019 (%)
	Emissions (Tons CO ₂ e)	(%)	Emissions (Tons CO ₂ e)	(%)	Emissions (Tons CO ₂ e)	(%)	Emissions (Tons CO ₂ e)	(%)	Emissions (Tons CO ₂ e)	(%)		
SCOPE 1 - Fuels	2 457	2.4%	2 842	2.2%	2 675	2.8%	3 805	4.1%	3 982	4.5%	4.7%	62.1%
SCOPE 1 - Refrigeration Gases	1 682	1.6%	1 625	1.3%	404	0.4%	464	0.5%	300	0.3%	-35.3%	-82.2%
SCOPE 1 - Total	4 139	4.0%	4 467	3.5%	3 079	3.2%	4 269	4.6%	4 282	4.8%	0.3%	3.5%
SCOPE 2 - Electricity	100 070	96.0%	122 791	96.5%	94 007	96.8%	89 444	95.4%	84 778	95.2%	-5.2%	-15.3%
TOTAL (SCOPE 1 + SCOPE 2)	104 209	100%	127 258	100%	97 086	100%	93 713	100%	89 060	100%	-5.0%	-14.5%

GREENHOUSE GAS EMISSIONS

Scope 1 emissions continue to represent a very small slice (5%) of our absolute emissions.

The reduction in our absolute emissions is due to a significant improvement in the use of renewable electricity, decreasing our scope 2 emissions

i Details of our scope 1 emissions and our scope 2 location-based emissions can be consulted in Appendix 02.

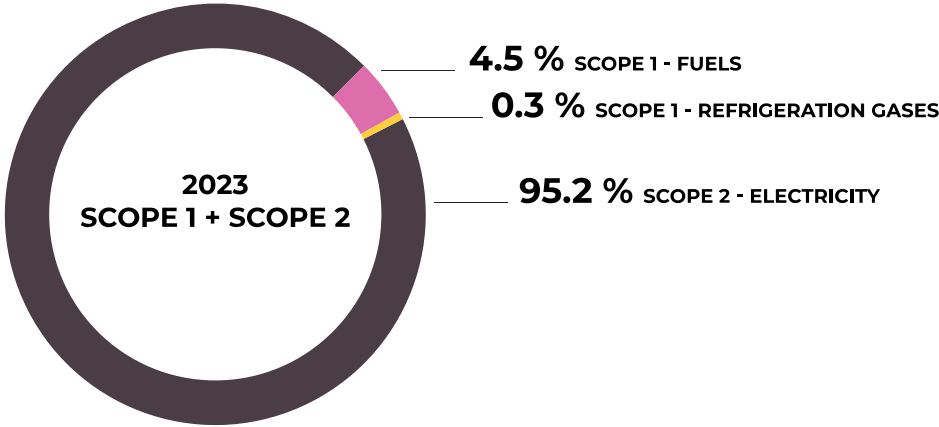

In addition to accounting our absolute scope 1 and scope 2 (market-based) emissions, in 2019 Logoplaste established a CORPORATE GHG EMISSIONS REDUCTION TARGET:

30% reduction of our operational CO₂e emissions by 2030 (base year 2019)

GREENHOUSE GAS EMISSIONS

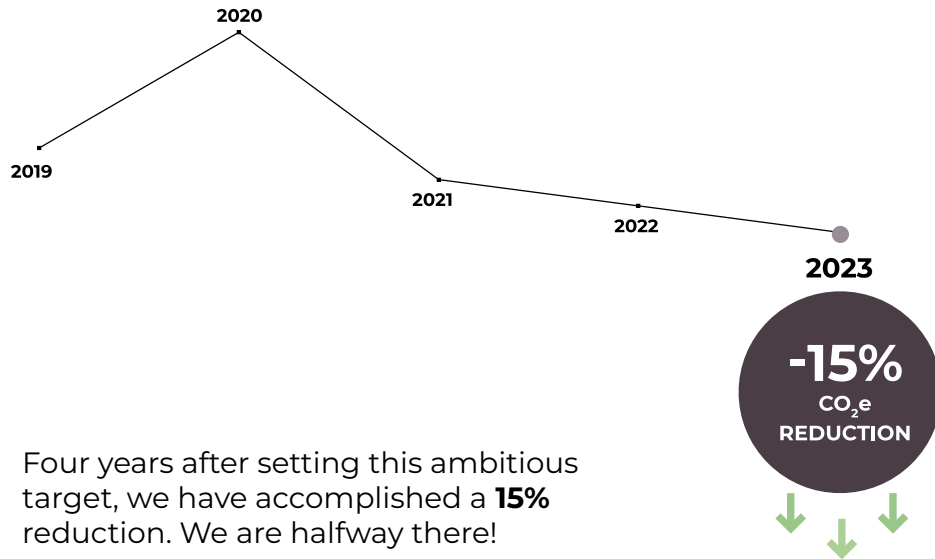

Logoplaste's Operational CO₂e Reduction Target

YEAR	Emissions (Tons CO ₂ e)	Variation from 2019 (%)
2019	104 209	-
2020	127 258	22%
2021	97 086	-7%
2022	93 713	-10%
2023	89 060	-15%

Important Note: values were reviewed due to updated electricity emissions factors and new methodologies for their calculations.

As Logoplaste's largest contributor to operational CO₂e emissions is electricity consumption, moving to renewable energy sources, and having central teams negotiating our energy supply contracts and evaluating energy related projects, was key to achieving this result.

To reach our target, we continue to work across all our sites to implement the best local solutions and in our wall to wall operations — where our customers decide on the electricity provider — we are working together to make the swap to less CO₂ intensive energy sources.



GREENHOUSE GAS EMISSIONS

Emissions Intensity

Coupled with our Operational CO₂e emissions target, Logoplaste defined an intensity indicator that shows the amount of CO₂e emissions from electricity usage relative to production (tonnage of raw materials transformed)*, setting a target for 2030:

30% reduction of our CO₂e intensity indicator by 2030 (base year 2019)

* The ratio between the CO₂e emissions resulting from electricity consumption and tonnage of raw materials transformed in the same period, for the plants that operated for the full year. Our calculations exclude plants that were starting up or closing during the reporting period.

In 2023, Logoplaste’s intensity indicator was 0.242 tons CO₂e / ton of raw material, representing an improvement of 12% compared to 2022 and an improvement of **37%** when compared to base year 2019. This 2023 result exceeds the established target.

Higher use of renewable energy along with energy efficiency initiatives, were the primary reasons for our intensity target accomplishment.

CO₂e emissions intensity indicator

YEAR	CO ₂ e Emissions Intensity Indicator	Variation from 2019 (%)
2019	0.383	-
2020	0.427	12%
2021	0.335	-13%
2022	0.274	-28%
2023	0.242	-37%

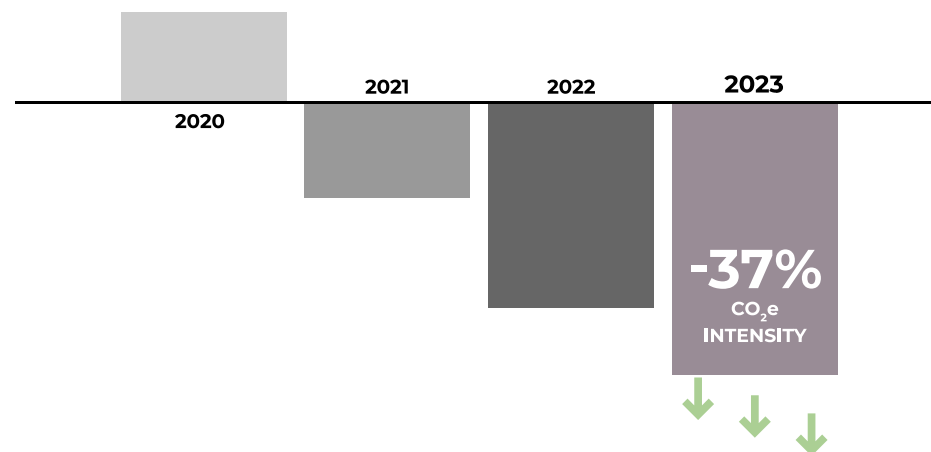

GREENHOUSE GAS EMISSIONS

Scope 3 greenhouse gas emissions

Scope 3 greenhouse gas (GHG) emissions cover indirect emissions resulting from Logoplaste's value chain activities.

Logoplaste's scope 3 emissions are greater than Logoplaste's operational GHG emissions.

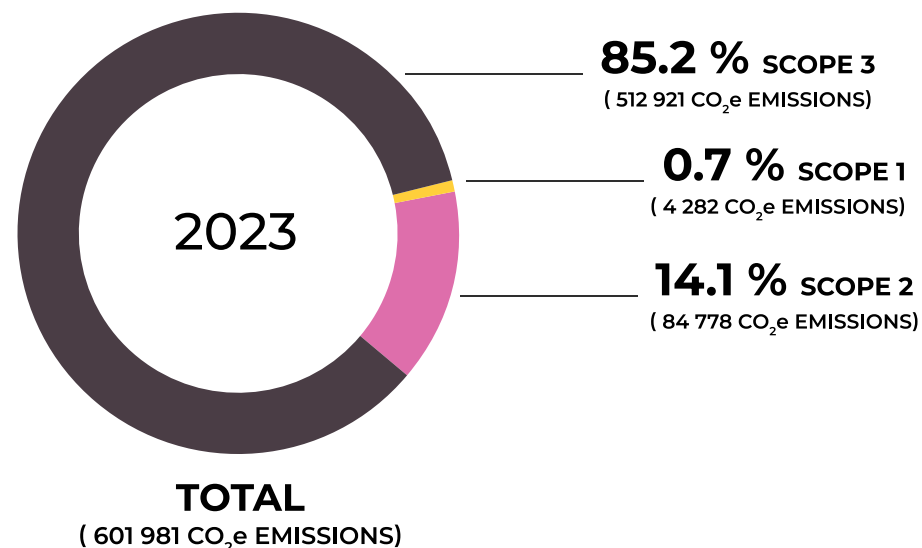

Comparison of Scope 1 and 2 Emissions with Scope 3 Emissions

	2022		2023	
	Emissions (Tons CO ₂ e)	(%)	Emissions (Tons CO ₂ e)	(%)
SCOPE 1	4 269	0.7%	4 282	0.7%
SCOPE 2	89 444	14.4%	84 778	14.1%
SCOPE 3	525 211	84.9%	512 921	85.2%
TOTAL	618 924	100%	601 981	100%

Logoplaste's largest category of Scope 3 GHG emissions is category 1, purchased goods and services, more precisely the purchase of raw materials used to produce packaging.

GREENHOUSE GAS EMISSIONS

Detail of Logoplaste's Scope 3 GHG Emissions in 2022 and 2023

Category:	2022		2023	
	Emissions (Tons CO ₂ e)	(%)	Emissions (Tons CO ₂ e)	(%)
Category 1 - Purchased goods and services	429 013	81.7%	424 630	82.8%
Category 2 - Capital goods	29 699	5.7%	21 778	4.2%
Category 3 - Fuel- and energy-related activities	25 763	4.9%	24 994	4.9%
Category 4 - Upstream transportation and distribution	27 687	5.3%	26 869	5.2%
Category 5 - Waste generated in operations	152	0.0%	139	0.0%
Category 6 - Business travel	1 611	0.3%	1 353	0.3%
Category 7 - Employee commuting	3 831	0.7%	4 006	0.8%
Category 8 - Upstream leased assets	0	0.0%	0	0.0%
Category 9 - Downstream transportation and distribution	3 071	0.6%	4 238	0.8%
Category 10 - Processing of sold products	0	0.0%	0	0.0%
Category 11 - Use of sold products	0	0.0%	0	0.0%
Category 12 - End-of-life treatment of sold products	4 385	0.8%	4 914	1.0%
Category 13 - Downstream leased assets	0	0.0%	0	0.0%
Category 14 - Franchises	0	0.0%	0	0.0%
Category 15 - Investments	0	0.0%	0	0.0%
TOTAL	525 211	100%	512 921	100%

As the majority of our GHG emissions result from the purchase of raw materials, resin choice; increasing incorporation of recycled content; evaluation of alternative recycled resins and bioplastics; and product design and lightweight programs, all of these play a significant role in Logoplaste's strategy to reduce our corporate carbon footprint.

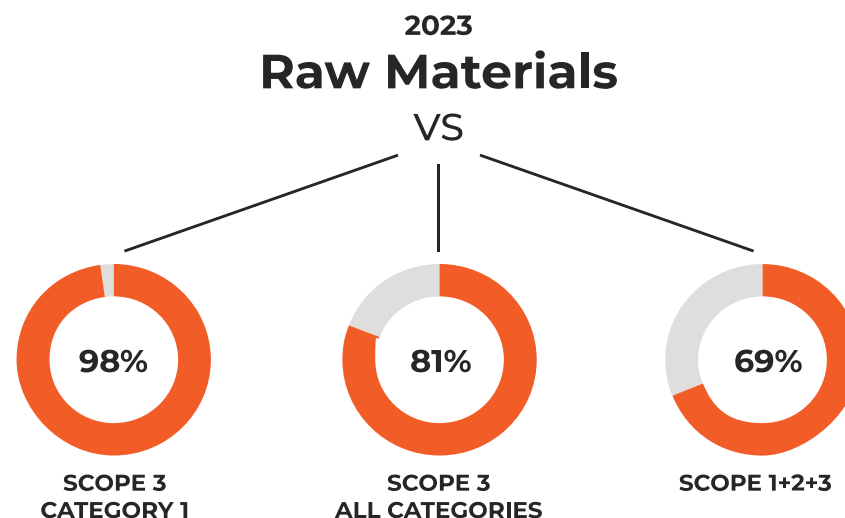

i The methodological process and assumptions for GHG Emissions calculation can be consulted in Appendix 03.

MATERIALS & PRODUCT CHARACTERISTICS

As demonstrated by our Scope 3 emissions, choosing the right resins to produce our packaging, and moving feedstocks away from fossil-based materials, will play a significant role in the reduction of our Corporate GHG emissions.

Logoplaste has been using recycled raw materials for over 10 years and in 2018 committed to further expand the incorporation of recycled content across product portfolio, by signing the **“The Global Commitment,” led by the Ellen MacArthur Foundation.**



Since 2019, we have seen an impactful increase in the percentage of recycled materials used by Logoplaste:

Recycled Raw Materials Consumption

	% PCR	% PCR PET	% PCR HDPE
2019	6.9%	10.4%	1.1%
2020	9.6%	13.5%	3.1%
2021	14.0%	18.8%	6.2%
2022	18.8%	25.2%	8.6%
2023	21.5%	28.2%	10.6%
2023 vs 2022	14.4%	11.9%	23.3%

PCR – post-consumer recycled

% PCR - total PCR materials transformed by total materials transformed

% PCR PET - PCR PET transformed by the sum of PCR PET transformed and virgin PET transformed

% PCR HDPE - PCR HDPE transformed by the sum of PCR HDPE transformed and virgin HDPE transformed.

Linked with the increase of recycled content, from 2022 to 2023, we observed a **1.5%** drop in CO₂e emissions resulting from our purchased raw materials, despite the **0.5%** increase in tonnage of processed raw materials.

This is related to the better eco-profile of recycled resins, compared to fossil-based resins.

CIRCULARITY

What is circular economy for plastic packaging?



Consumers buy products



Consumers dispose of packaging in appropriate collection points



Waste collectors separate and send to recyclers



Recyclers deliver recycled resin



Logoplaste produces bottles with recycled material

RecyClass + Bureau Veritas

Logoplaste Innovation Lab and Bureau Veritas Portugal have formed a strategic partnership as an Authorized Certification Body for RecyClass Certifications, where we can assess **Plastic Packaging Recyclability**, as well as quantify **Plastic Recycled Content** for any product.

This means we can help in the improvement of our Client's plastic packaging recyclability performance and calculate the share of plastic recycled content in various objects, from a bottle to a chair, so that truthful, as well as reliable, claims can be made.

We assess products so they are a perfect fit for the circular economy of plastics.

Recyclass Certifications are Europe's undisputed seals of approval for **Recycled Plastic**, ensuring packaging and products live up to their sustainable claims and targets.



■ CIRCULARITY

ISCC Plus

If you want to go fast, go alone; if you want to go far, go together

This African proverb could not be truer when it comes to Circularity, as only by working together, following the same guidelines and integrating seamlessly with the other market players, can we all have a significant positive impact.

ISCC* PLUS is an international sustainability certification scheme applicable to bioeconomy and the circular economy for food, feed, chemicals, plastics, packaging, textiles, and renewable feedstock derived from a process using renewable energy sources. All kinds of biomass, waste and residues, non-biological renewables and recycled carbon-based materials can be certified under ISCC PLUS.

ISCC Plus certification ensures that sustainable materials are traceable throughout international supply chains. Logoplaste, a pioneer in the usage of recycled content, has the following plants certified in ISCC Plus:

- Logoplaste Estarreja, Portugal
- Logoplaste Guadalajara, Spain
- Logoplaste Leeds, UK
- Logoplaste Dumfries, UK
- Logoplaste Vienne, France

All that we do aligns with our purpose, can be measured, reported and audited. At Logoplaste, we work in black and white, there are no gray areas. This is how Circularity will win.

*International Sustainability and Carbon Certification





WATER

Making every drop count

In 2023 our total water withdrawal was 244 ML (megaliters), with 56% from the public supply network and 44% from groundwater.

In 2023 our water withdrawal slightly decreased by 4% (compared to 2022).

Our recycling plants, Ecoibéria and WorldPET contribute to 55% of our water withdrawal, as recycling is a water intensive process.

We use Aqueduct’s Global Water Risk Mapping tool from the World Resources Institute (WRI) to understand which plants operate in high water-stressed areas so we can implement tailored actions.

In 2023, Logoplaste withdrew 56 ML of water from areas with high to extremely high-water stress, a 20% decrease from 2022, and corresponds to **23%** of Logoplaste’s total water withdrawal in 2023.

Water withdrawal by source

Water Withdrawal Source	2022		2023		2023 vs 2022 (%)
	Water Withdrawal (ML)	(%)	Water Withdrawal (ML)	(%)	
Third party water	129	51%	136	56%	5%
Groundwater	125	49%	108	44%	-14%
Total	254	100%	244	100%	-4%

■ WATER

Every single pellet is accounted for.

Attention to detail is how you keep, and maintain, a clean environment.

Operation Clean Sweep aligns with government requirements in France. Thomas Bienfait is proud to share what they have done.

“Since 2016 Logoplaste France has been part of OCS – Operation Clean Sweep. Logoplaste Cambrai, Logoplaste Lons and Logoplaste Vienne have all signed the letter of commitment, pledging to this noble initiative.

But that is not all, tailored technical as well as procedure improvements, training and awareness have been implemented for our teams and key stakeholders, so that everyone along the supply chain is onboard with preventing pellet and flake loss. We have also shared this project with our customers, so together we can strengthen our risk assessments and define joint actions.

All these measures enabled us to obtain the “Prevention of Loss of Industrial Plastic Granules” (GPI) Certification for each site in 2022, just a few months after the publication of French decree 2021-461.

All our teams are involved, and new arrivals are made aware of this as soon as they join Logoplaste. Obtaining the certification

and keeping it requires constant attention to details, when the entire team is on the same page, everyone can contribute to protecting our environment on a daily basis.

Only together can we shape a better environment!



Thomas Bienfait
Quality & EHS Manager
France & Belgium

WASTE

From scrap to value, a useful resource

In 2023, Logoplaste produced a total of 6 827 tons of operational waste, 98% of which was sent for recycling or reuse.

Hazardous waste represents 4% of our total operational waste. Our main sources of hazardous waste are used oils and lubricants, rags and other absorbents used for spill cleanups.

Breakdown of type of waste by disposal method

TREATMENT / DISPOSAL METHOD	HAZARDOUS WASTE		NON-HAZARDOUS WASTE		TOTAL	
	Quantity (Tons)	(%)	Quantity (Tons)	(%)	Quantity (Tons)	(%)
Recovery - Preparation for Reuse	9.8	3.6%	1 454.5	22.2%	1 464.3	21.4%
Recovery - Recycling	226.5	82.2%	5 012.2	76.5%	5 238.7	76.7%
Disposal - Incineration with Energy Recovery	15.9	5.8%	23.2	0.4%	39.1	0.6%
Disposal - Incineration without Energy Recovery	12.7	4.6%	0,0	0.0%	12.7	0.2%
Disposal - Landfill	5.2	1.9%	26.3	0.4%	31.5	0.5%
Stored on-site*	5.3	1.9%	35.2	0.5%	40.5	0.6%
ALL METHODS	275.4	100%	6 551.4	100%	6 826.8	100%

*waste stored on site



■ WASTE

The importance of an ERA Action Plan

Environmental Risk Assessment is key for continuous improvement

In 2022 Logoplaste's sites completed their first global Environmental Risk Assessment, aka ERA, with an online survey, with 45 questions. The responses gave a precise vision on what actions plans needed to be implemented.

This assessment identified 235 opportunities for improvement in the following areas:

- Electricity, water and gas meters
- Dealing with local and accidental spillages
- Hazardous, Non-hazardous and electrical waste control
- Site standards
- Environmental awareness training

In the third quarter of 2023 a progress evaluation was conducted. Of the 235 tasks, 114 actions had been accomplished, which represents a completion rate of 49%.

In 2024 we will continue working on the remaining tasks.

The environmental risk assessment is an essential aspect of our operations and helps support the decision-making process.

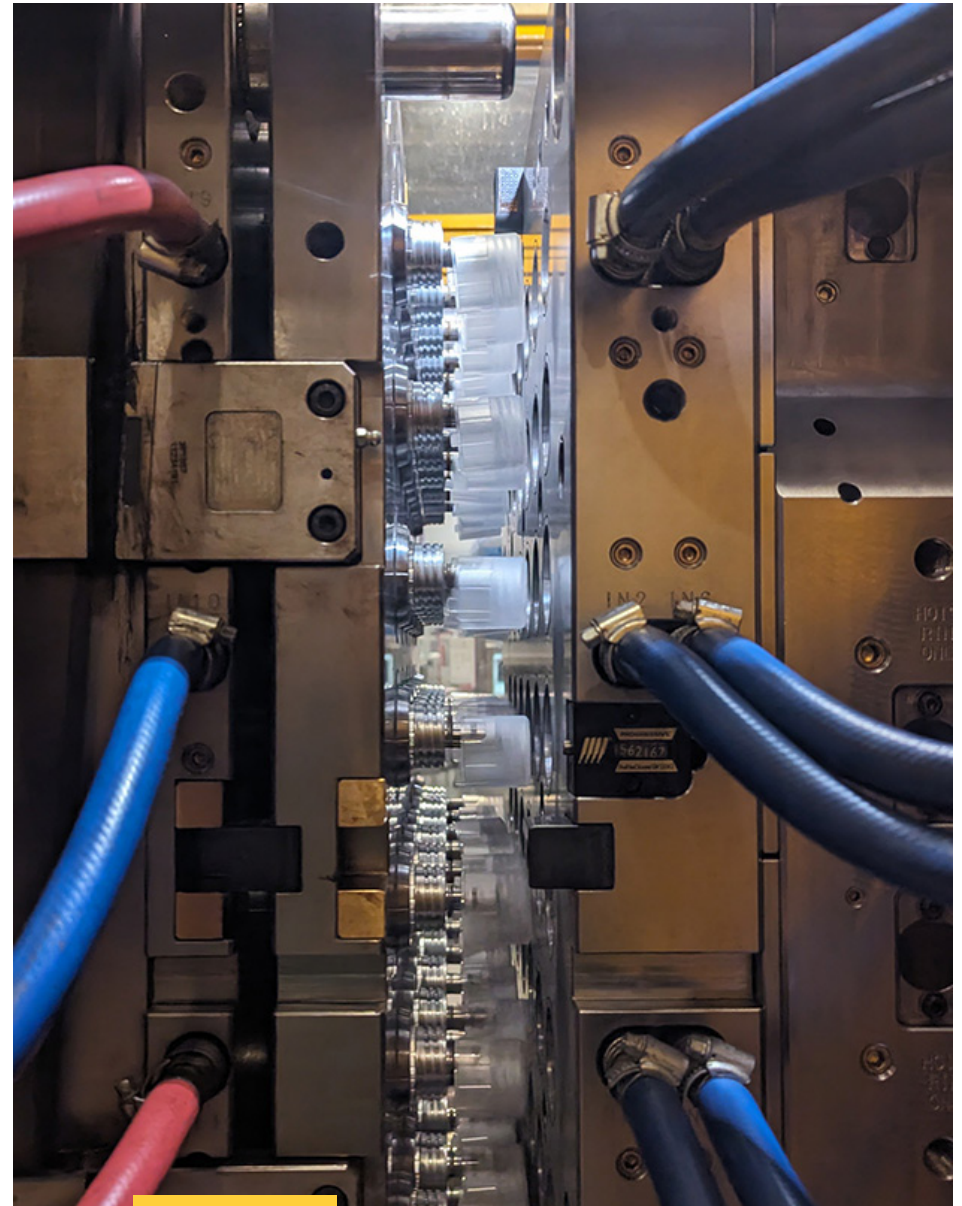



SAFETY

NON-NEGOTIABLE

At Logoplaste safety is our n° 1 priority

As an industrial company, the safety of all staff is not only a priority, it is the company's main concern.

At the end of every shift, all employees must return home, to their loved ones, safely – this means physically unharmed and mentally strong.

Our goal is to ensure the health and wellbeing of every single employee, contractors, customers, and the surrounding communities.



■ NON-NEGOTIABLE

Kevin Morgan, Logoplaste’s Global Director for EHS, explains how the Cardinal Rules help achieve this non-negotiable objective:

“At Logoplaste, our Cardinal Rules stand as fundamental pillars in fostering a culture of safety across all environments. These rules serve as guiding principles aimed at preventing accidents and incidents, while at the time promoting wellbeing.

Central to our safety ethos is the recognition of both individual responsibility and collective teamwork. All employees at Logoplaste bear the duty to prioritize safety in their actions, understanding that no task is worth risking injury. Simultaneously, we emphasize the importance of peer-to-peer safety, encouraging everyone to watch out for each other’s safety.

Adherence to the Cardinal Rules is paramount. By consistently upholding these principles, we not only safeguard our own welfare but also contribute to the safety of our colleagues and the workplace at large.

Emphasizing both individual responsibility and collective teamwork reinforces the message that safety is a shared commitment. It fosters active participation, instills a sense of accountability, and cultivates a safer and healthier environment for all.

At Logoplaste, safety is not just a priority—it’s a collective responsibility we uphold with unwavering dedication.



Kevin Morgan
Global EHS Director

OUR CONTINUOUS OHS IMPROVEMENT IS BASED ON 6 FRONTS:

1. QEHS POLICY

The QEHS policy describes our vision and provides a framework for developing our management systems. The policy is reviewed annually and approved by our CEO. All sites communicate this policy with their teams and develop suitable action plans.

2. OHS MANAGEMENT SYSTEMS & CERTIFICATIONS

All our plants comply with OHS management systems' legal requirements for full-time, temporary and agency employees. To further continue our safety standardization, we have been gradually certifying sites according to ISO 45001 international standard, starting with those that have the highest number of employees. In 2022 as part of our Digital Operation strategy, we developed a standardized internal audit and inspection module. This creates standard audit and inspections across all plants and enable these processes to be digitalized (no manual records).

3. LOCAL & GLOBAL HEALTH AND SAFETY PERFORMANCE

We use a risk assessment process that identifies hazards in the workplace which are then analyzed by the plant managers and their teams. Together, they develop and implement immediate safety systems and action plans.

4. ENGAGEMENT WITH TEAMS

Each site holds regular meetings with all team members. The sessions address local performance, improvement plans, accidents, and potential changes in the workplace. Meeting minutes and action plans are posted.

The use of safety hazard (unsafe conditions*) reporting is key in employee engagement, enabling teams to identify hazards, making the workplace safer. Since 2022 we use a standardized reporting system to record safety hazards via our EHS intranet page.

**An unsafe condition is anything with the potential to cause harm, injury and/or damage.*

■ NON-NEGOTIABLE

5. TRAINING

Training needs are clearly identified in the Global Training Matrix and all Logoplaste employees receive regular training suited to their role.

Training is delivered in the workplace during working hours whenever possible. Training effectiveness is measured through on-the-job tasks and simulations.

6. EXECUTIVE SAFETY COUNCIL

Logoplaste's Executive Safety Council's goal is to reduce incidents, injuries, illnesses, and ensure that all facilities have the safest and healthiest environment possible for its employees.

With representatives from various areas, the ESC meets once a month and ensures decisions are implemented and followed through.

OHS METRICS

Think safety, act safely

Being Proactive

Any action taken to make the workplace safer, this includes safety hazard spotting, risk assessment, safety talks, and safety inspections.



OHS METRICS

Our Health & Safety tools

Actions taken to prevent injuries, harm and ill health in 2023



2 671

SAFETY HAZARDS CLOSED



2 240

SAFETY HAZARDS ACTIONS



268

SAFETY HAZARDS STILL OPEN



4 288

SAFETY TALKS



1 849

SAFETY TEAM MEETINGS



4 679

RISK ASSESSMENT



3 946

SAFETY INSPECTIONS



19 941

TOTAL NUMBER OF PROACTIVE

OHS METRICS

Health & safety tools - coverage

	Coverage 2021 (%)	Coverage 2022 (%)	Coverage 2023 (%)
Plants using risk assessments	76%	95%	96%
Plants recording safety hazards	93%	96%	82%
Plants performing safety talks	81%	97%	99%
Plants completing safety team meetings	81%	100%	99%
Plants performing safety inspections	82%	100%	99%

Report a Hazard
 Before you have to report an injury

■ OHS METRICS

Being Reactive

An injury that has been included in our TRIR reporting such as medical treatments, restricted work and lost time accidents.



OHS METRICS

Number of work-related injuries and ill health

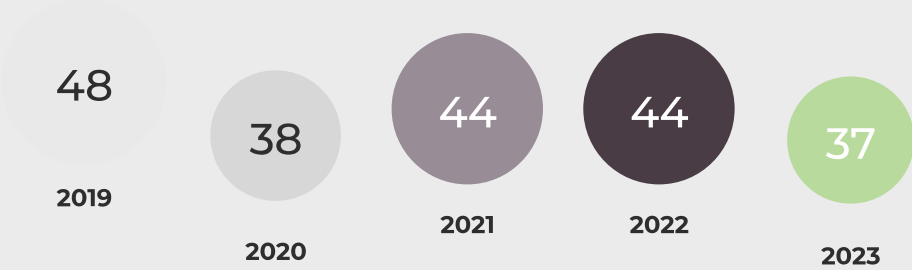

Number of hours / Number of days lost

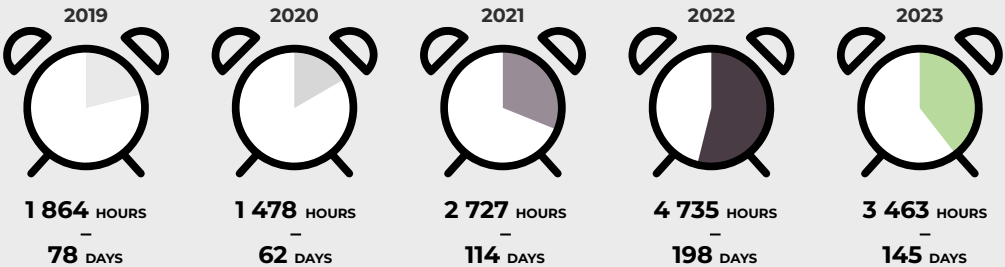

Logoplaste Safety Triangle in 2023

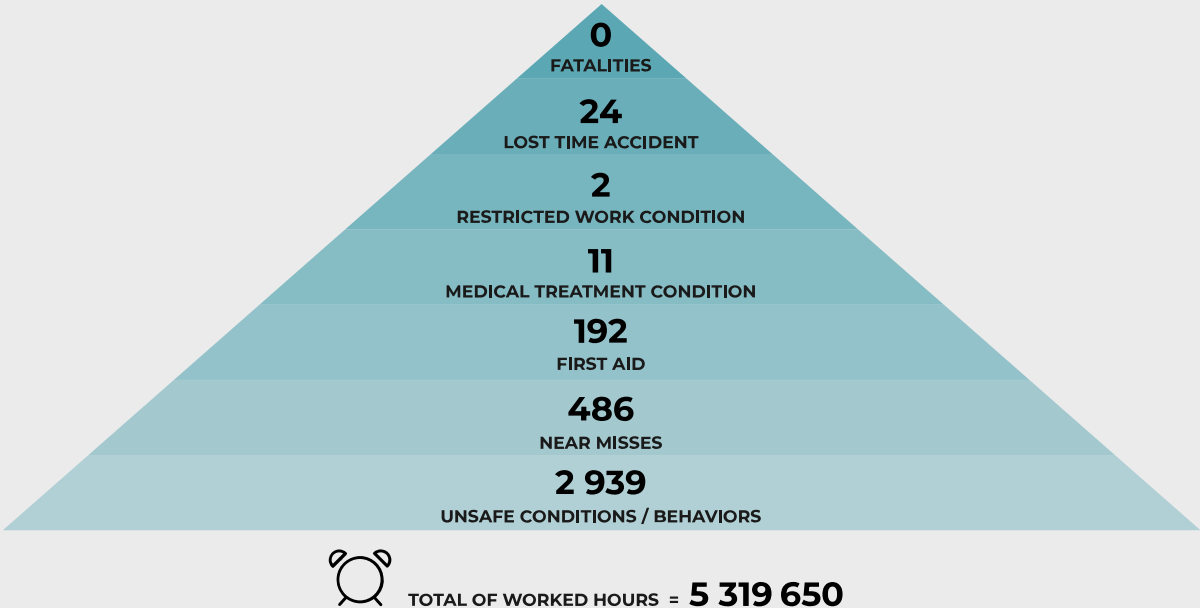

OHS METRICS

TOP 3 INJURIES BY QUANTITY



TOP 3 INJURIES BY HOURS LOST TIME

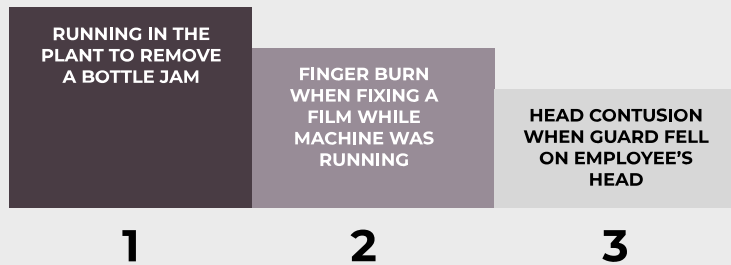

Safety criteria measurement and monitoring

(per 200 000 h)	Rate					
	2019	2020	2021	2022	2023	2023 vs 2022
TRIR - Total Recordable Incident Rate	2.2	1.7	1.8	1.7	1.4	✓
FR - Fatality Rate	0	0.0	0.0	0.0	0.0	=
ODR - Occupational Disease Rate	0	0.0	0.0	0.0	0.0	=
Lost Time IR	NR*	1.0	1.1	1.2	0.9	✓
LWR - Lost Workday Rate	3.5	2.7	5.1	7.7	5.5	✓

TRIR* Evolution

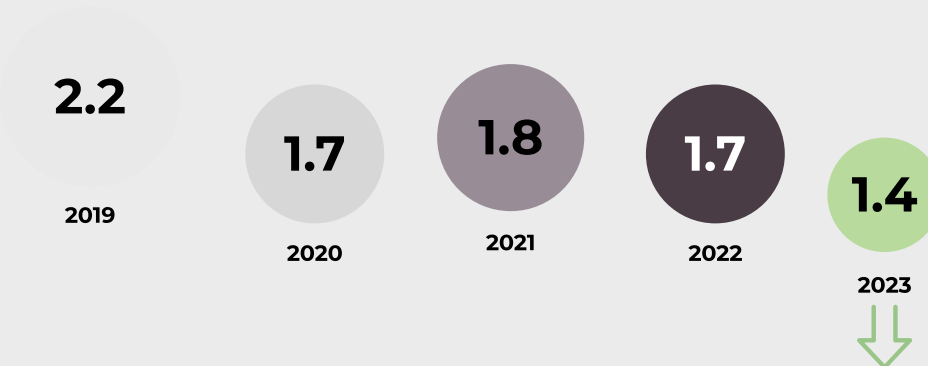

* calculated based on 200 000 hours worked

Note: All numbers reported above include employees, temporary and agency workers



PEOPLE

ENGAGEMENT

It is up to us to provide a positive experience for our teams

Attitude, motivation & drive

Logoplaste needs to create an environment that is engaging, inclusive and promotes growth both at a professional level as well as personal.

The success of our employees is the basis for our own.



It's all about keeping the curiosity level high

Taking care of our team, means keeping them safe, interested and driven.

Delivering sustainable, quality, innovative packaging requires dedication, skill, attention to detail and commitment.

This can only be achieved in a work environment that is welcoming; with a leadership team that always puts people first, looking at the individual needs and ambitions.



AT LOGOPLASTE WE WORK TOGETHER, AND WE DO IT WELL

Since the first contact, Logoplaste has a well-defined plan for each person:

1 .THE RIGHT FIT

- Discovering and attracting top talent
- Matchmaking – hiring based on attitude
- Hiring Managers – train and empower so they recognize the perfect fit
- Equal opportunities – internally and externally, driven by diversity, equity & inclusion

“We scout for talent and hire on attitude.”

2 . INDUCTION, ORIENTATION & ONBOARDING

- The wow factor – constant improvement of new hire journey and experience
- Never let go – starting with day 1 and until the new hire is fully settled in
- Culture imprint – corporate values, company purpose and objectives, knowledge sharing, networking, processes & procedures compliance, and having fun

“The goal is to transform new hires into confident, engaged, pro-active employees.”

3 . TRAINING & DEVELOPMENT

- Logoplaste Leadership Academy
- Training Matrix – focused on operational positions
- Mandatory trainings – all on the same page
- Tailored courses for specific skills and competences
- Upon request – teams can propose trainings based on individual needs

“Knowledge is power”

4 . PERFORMANCE MANAGEMENT

Logoplaste’s individual performance management system, allows for a transparent evaluation. Objectives are set, based on clear and agreed upon goals. There is a mid-year evaluation, an employee self-assessment and a final manager review.

ACHIEVE is an ongoing and continuous process of check-in conversations, communicating and clarifying responsibilities, priorities and performance expectations in order to ensure mutual understanding between manager and employee.

“Aligning personal expectations with company objectives is key for a successful employee/employer relations.”

■ ENGAGEMENT

5 . PAY & BENEFITS

Logoplaste ensures that compensation and benefits are compliant with each country's regulations

- Compensation practices are reviewed annually by an external entity
- Benchmarking is performed to understand internal equity and external competitiveness
- Global Guidelines and Policies to ensure we are compliant with labor and wages regulations across all countries, never compromising fair treatment of our employees.

As in any company, compensation plays an important role when it comes to employee engagement

“External Benchmark and Performance Management help drive pay for merit approach.”

6 . CULTURE & ENGAGEMENT SURVEY

We believe a positive Employee Experience is key to promote engagement.

The Employee Engagement Survey, aka Engage, is a way to collect employee's honest, anonymous, feedback. A way for Logoplaste to “listen” to employees' experience in the company.

“Feedback from the teams is essential for continuous improvement and engagement.”

INVOLVEMENT & PARTICIPATION

It's all about being present and connecting with those around us, whether within Logoplaste or with our local communities.



Finding the time to get it all done

Matheus Bortarelli, from Logoplaste Amparo Brazil, organized his shifts with this manager, José Elias, so he could attend an 80-hour training on Plastic Injection.

Everyone benefits, including Matheus as he increases his knowledge and skills. At Logoplaste, training is part of daily activities.



Shaping young talent

Ines Fernandes, INOV CONTACTO trainee, stationed at Logoplaste Lima, USA:

“From the first moment I had the onboarding in Cascais, I felt welcomed. Arriving in the US I had support with logistics and a warm welcome at the plants I was in. At Lima, I feel part of the team and I contribute in the discussions.”

Supporting young talent today, so it becomes great talent tomorrow.



Supporting sports

Logoplaste Thurrock, UK, supports Grays Athletic Youth FC, Under 16.

The Under 16 Blues play in the Echo Junior Soccer League B division, and they are off to a steady start with 2 wins, 2 draws, and only 1 loss.

Supporting local communities is something we like to do.

ENGAGEMENT



Trying new things is good for you ;)

Terry Wingate asked Beth Siebers to organize a dinner for the Plainfield team to show appreciation for all the work and commitment.

The event took place at Shinto's Hibachi. A friendly wager was placed between 2 employees, and Jose Madrigal lost the bet: he had to try sushi for the first time, and guess what? He loved it!



High School Students & Quality

The High School work experience in Cascais, Portugal.

Vera Oliveira, Metrology and Quality Manager, and her trainee, Gonçalo, in the Quality lab.

Helping high school students get a feel for the work environment with a 2 week "hands-on" program. Supporting young talent today, so it becomes great talent tomorrow.



Safety & Halloween go hand in hand

The UK implemented a pumpkin carving contest with a "safety" component. Pumpkin carving had to be conducted following Logoplaste's safety guidelines... waste disposal, PPE usage, proper procedures, and end results report.

The UK Plants took the mission seriously, getting families & colleagues involved.

ENGAGEMENT



When asked, everyone says “yes”

Logoplaste Araras I & Araras II carried out a joint initiative, collecting body wash and sunscreen cream for ALARA - an association that supports women with cancer.

Supporting our local communities shows who we are as a company.



Seeing young talent thrive is very rewarding

Billy Wright presents Jack Sornat with his certificate for the successful completion of his 4-year Engineering Apprenticeship at Logoplaste Leeds.

Jack is now a fully qualified multi-skilled engineer with HNC and NVQ Level 3 qualifications. But that is not all, he has been integrated into a shift, and is part of the wider Leeds Engineering Team.



Spending time together is good

Kansas City goes out & about with families, friends, and colleagues.

Everyone had a great time bowling, playing games, eating, and just being together. For Steven Mayer and Kari Niccum, this is an important part of the plant's routines.

HR METRICS

Looking at our HR KPIs gives us a clear picture of where we stand

In 2023 our headcount increased by 4.2%, with 2 692 employees vs 2 584 employees in 2022.

This increase was mainly in the United States (51 out of 108 employees) due to growth in this region. We can also see an upward trend in Portugal, Poland and Mexico.

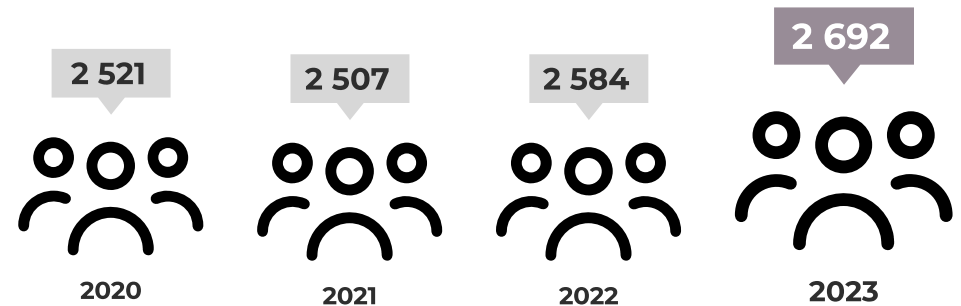

Total number of employees by region and gender

Region	Female	Male	Total	%
Americas	310	972	1 282	47.6%
Europe & AP	339	1 071	1 420	52.4%
Total	649	2 043	2 692	100.0%

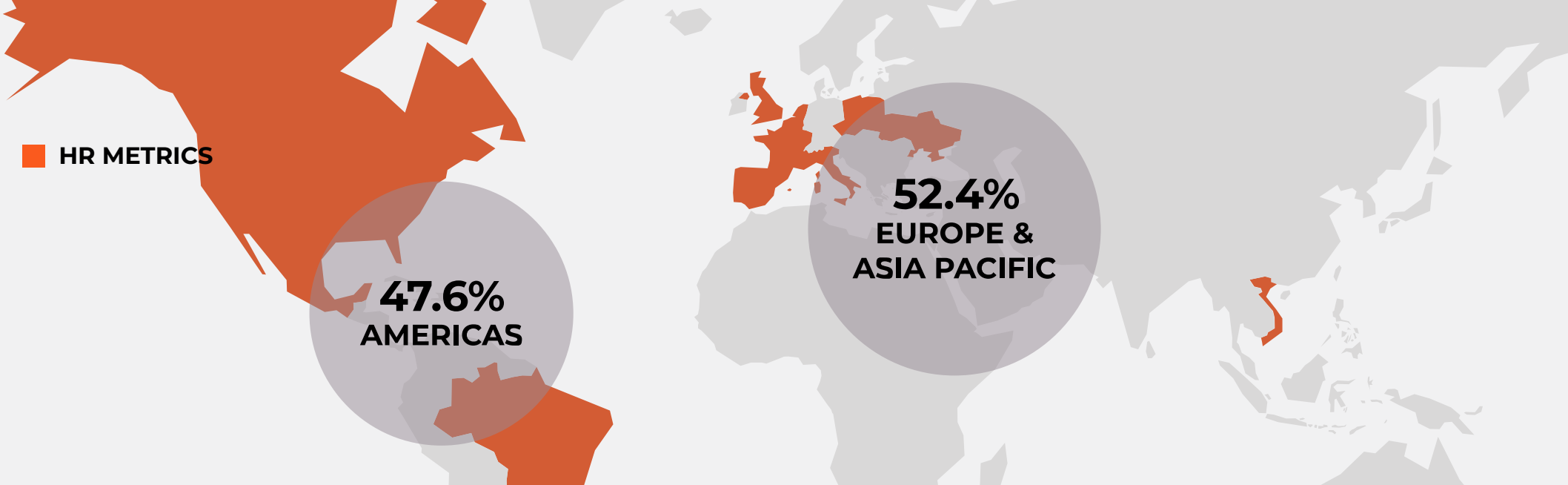

Distribution of Logoplaste’s employee population continues to be balanced between The Americas (47.6%) and Europe & Asia Pacific (52.4%).

Total number of employees by region and contract type

Region	Contract type		Total
	Fixed Term	Permanent	
Americas	3	1 279	1 282
Europe & AP	91	1 319	1 410
Total	94	2 598	2 692

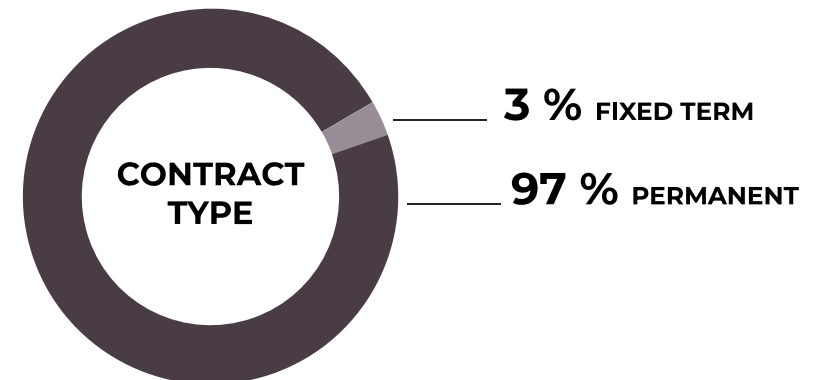

i Details by country can be consulted in Appendix 04.

HR METRICS

Total number of employees by contract type and gender

Contract Type	Female	Male	Total	%
Fixed Term	27	67	94	3%
Permanent	622	1 976	2 598	97%
Agency Staff*			213.3	
Total**	94	2 598	2 692	100%

Total number of employees by employment type and gender

Employment Type	Female	Male	Total	%
Full-Time	637	2 030	2 667	99%
Part-Time	12	13	25	1%
Total	649	2 043	2 692	100%

* Temporary (average agency staff in 2023)

** Only Logoplaste Employees, excluding agency staff

There are no significant changes in gender ratio and employment contract type ratio, when compared to previous years.

97% of our workforce has a permanent contract and fulltime employees continue to represent 99% of the workforce employment type. Increase of 36.7 FTE's in agency staff when compared to 2022.

These numbers demonstrate that Logoplaste is a good place to work, where long term relationships are valued. This is part of the secret to our success, where employment duration and signed contracts are a mark of your commitment to our team and vice-versa.

HR METRICS

Number and percentage of employees by gender, per employee category

Employee Category	Female	Male	Total	%
Operational & Technical	387	1 295	1 682	62.5%
Clerical & Office	54	21	75	2.8%
Professional	130	291	421	15.6%
Supervisory & Managerial	67	385	452	16.8%
Senior Management	8	39	47	1.7%
Executive	3	12	15	0.6%
Total Employees	649	2 043	2 692	100%

There are no significant changes in these categories. The ratio of women slightly increased, representing 24.1% of the total workforce in 2023 vs 23.3% in 2022. We can see a slight increase in ratio male/female in Executive & Senior Management from 17.5% in 2022 to 17.7% in 2023.

The majority of employees (62.5%) are in operational and technical roles.

A small portion of the workforce (2.8%) is in clerical and office roles, and this is the category with a higher female representation: 54 females (72%) and 21 males (28%).

We continue to focus our efforts in hiring a more balanced and gender-diverse workforce, as seen in the "new hire ratio" section.

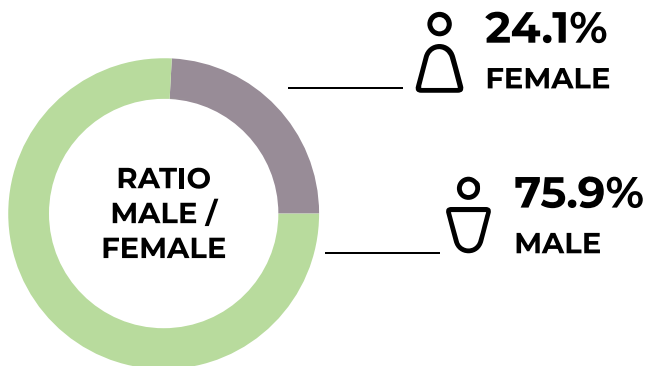

	Female	Male
Ratio in Executive & Senior Management positions*	0.4%	1.9%
Ratio in Executive & Senior Management positions**	17.7%	82.3%

*of Total headcount

**of Total Senior Management & Executive Positions

HR METRICS

Number of employees by age category, gender, per employee category

Employee Category	Between 18 & 30 y		Between 31 & 40 y		Between 41 & 50 y		Between 51 & 60 y		More than 61 y		Total
	Female	Male	Female	Male	Female	Male	Female	Male	Female	Male	
Operational & Technical	76	301	121	386	122	328	58	212	10	68	1682
Clerical & Office	11	6	14	9	18	4	10	1	1	1	75
Professional	20	49	53	98	35	86	20	46	2	12	421
Supervisory & Managerial	6	21	22	106	21	133	13	99	5	26	452
Senior Management			2	2	3	18	1	17	2	2	47
Executive					2	7		4	1	1	15
Total	113	377	212	601	201	576	102	379	21	110	2 692
%	4.2%	14.0%	7.9%	22.3%	7.5%	21.4%	3.8%	14.1%	0.8%	4.1%	100.0%

NUMBER OF EMPLOYEES BY AGE CATEGORY AND GENDER IS VERY SIMILAR TO PREVIOUS YEARS

This shows a mature and experienced workforce, helping with training programs, knowledge sharing, and skills transfer within Logoplaste Operations.



41.8

AVERAGE AGE
Years old



6.8

AVERAGE TENURE
Years of service

HR METRICS

As stated in our **CODE OF CONDUCT**, Logoplaste respects the freedom of association, recognizes the right to collective bargaining, providing parallel resources for free and independent association and ensures that union members and representatives of workers are not subject to discrimination, and that such representatives have reasonable access to their members in the workplace.

Collective agreements by country and number of employees covered

Country	Number of Employees	Collective Agreement Detail
Belgium	18	Commission Paritaire De L'Industrie Chimique (116) & Commission paritaire pour employés de l'industrie chimique (207)
Brazil	390	Convenção Coletiva dos Trabalhadores das Indústrias Químicas e Farmacêuticas
France	61	Convention Collective Nationale de la Plasturgie
Italy	33	Contratto Collettivo Nazionale Di Lavoro Industria Chimica
Portugal	416	Contrato Coletivo de Trabalho (CCT) do Setor Químico
Spain	70	Convenio Colectivo General De La Industria Química
Total	988	36.7%
Total Employees	2 692	

HR METRICS

KEEPING THE TEAM MOTIVATED IN A VERY COMPETITIVE MARKET

Turnover by region

Region	Number of Leavers	Average EE's	Turnover %
Americas	441	1 266.8	34.8%
Europe & AP	273	1 390.1	19.6%
Total	714	2 656.9	26.9%

TURNOVER METRICS

*Turnover % is the calculation of the number of leavers during 2023, divided by the average headcount during the same period. Figures have been calculated based on the average number of Employees (average EE's) during 2023, in relation to each geographical area, gender and age group.

Comparing the 2023 turnover rate of 26.9%, to the 2022 rate of 29.3%, we see a reduction. This is a positive indicator of our efforts to enhance employee engagement and retention. However, the high turnover in the age group 18-30 years (42.6%) is a priority for HR initiatives.

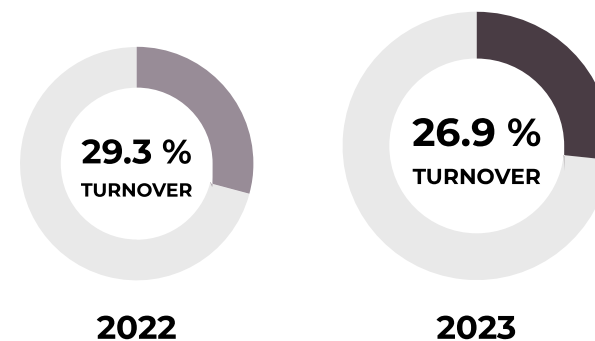

i Details by country can be consulted in Appendix 04.

The number of leavers in 2023 decreased when compared to 2022: 714 leavers in 2023 vs 746 in 2022.

The region with the highest turnover is the Americas, with the United States reaching 47.1% of turnover.

HR METRICS

The high turnover in France is primarily attributed to the closure of one of our plants in the region. In Vietnam turnover was 37.9% and is expected to remain high in the upcoming years, as the country has increasing job opportunities within the industry.

Although there has been a slight decrease in turnover, and despite our efforts, the industry faces high turnover rates. Factors such as the nature of shift work, the ongoing global skill

Turnover by gender

Gender	Number of Leavers	Average EE's	Turnover %
Female	161	621	25.9%
Male	553	2 036	27.2%
Total	714	2 657	26.9%

Male employees have a slightly higher turnover rate (27.2%) compared to female employees (25.9%).

The highest turnover rate is observed in the 18-30 years age group at 42.6%.

Turnover rates decrease progressively with age, with the lowest rates in the 41-50 and 51-60 years age groups, both at 19.6%.

Employees aged more than 61 years have a turnover of 21.9%,

shortage, and the intense competition for talent, are strong contributors.

We are committed to addressing these challenges through targeted strategies, including improving employee engagement, comprehensive training programs, and competitive compensation packages, to improve retention and ensure a stable and motivated workforce.

Turnover by age group and gender

Age group	Female	Male	Total Leavers	Average EE's	Turnover %
Less than 18 yrs	0	0	0	0	0.0%
Between 18 & 30 yrs	46	162	208	487.8	42.6%
Between 31 & 40 yrs	61	174	235	800.9	29.3%
Between 41 & 50 yrs	30	120	150	766.7	19.3%
Between 51 & 60 yrs	18	74	92	469.1	19.6%
More than 61 yrs	6	23	29	132.4	21.9%
Total	161	553	714	2 656.92	26.9%

mainly due to retirement reasons. This is a reality for Portugal, where employees have a high tenure in the company.

The age group with the highest turnover is also the same with the highest hiring rate (53.5% of total hires), especially in Operations.

HR METRICS

NEW HIRES METRICS

*New Hires % is the calculation of number of starters during 2023, divided by the average headcount during the same period.

Figures have been calculated based on the average number of Employees (average EE's) during 2023, in relation to each geographical area, gender and age group.

New hires by region

Region	Number of New Hires	Average EE's	Ration New Hires %
Americas	404	1 266.8	39%
Europe & AP	312	1 390.1	22.4%
Total	806	2 656.9	30.3%

New hires by gender

Gender	Number of New Hires	Average EE's	Ration New Hires %
Female	211	621	34%
Male	595	2 036	29.2%
Total	806	2 657	30.3%

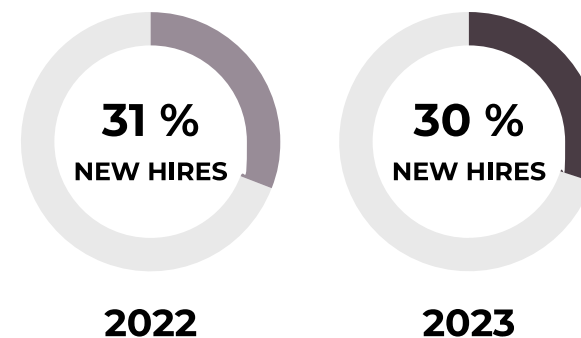

i Details by country can be consulted in Appendix 04.

HR METRICS

New hires by age group and gender

Age group	Female	Male	Total New Hires	Average EE's	New Hires %
Less than 18 yrs	0	0	0	0	0.0%
Between 18 & 30 yrs	60	201	261	487.8	53.5%
Between 31 & 40 yrs	68	203	271	800.9	33.8%
Between 41 & 50 yrs	54	111	165	766.7	21.5%
Between 51 & 60 yrs	23	64	87	469.1	18.5%
More than 61 yrs	6	16	22	132.4	16.6%
Total	211	595	806	2 656.9	30.3%

The number of new hires increased by 2% when compared to 2022 -more 15 new hires than in 2022.

Female new hire ratio is 34.0%, which is slightly higher than the male new hire ratio of 29.2%. This shows our efforts to recruit more female employees contributing to a more balanced gender diverse workforce.

As mentioned, the highest new hire ratio, is within the 18-30 years, at 53.5%, indicating a strong focus on recruiting younger employees. The significant hiring in the 31-40 years age group also indicates that we are targeting experienced professionals who can contribute immediately to our business.

Countries with higher % of new hires were USA, Netherlands and United Kingdom.

The overall new hire ratio is 30.3%, reflecting substantial recruitment activities across regions, genders, and age groups.

When we look at new hires versus turnover, our pattern continues to be aligned with our industry peers. Job opportunities are abundant and candidates, with specific skillsets, are few.

Plastic packaging is a competitive market for top talent people, especially in the Americas, with higher turnover and hiring rates.

HR METRICS

CONSTANTLY LEARNING

Everyone at Logoplaste is a student and a teacher - it's baked into who we are. The pace of innovation in our industry means every day is filled with new things to master. As you grow, we'll be there for you with training, coaching, and opportunities for professional development.

Every year we invest in Training & Development, aligning with our business priorities and growth.

Training given by external entities, but also training on the job, knowledge sharing, online and face to face, coaching and mentoring, are some of the learning opportunities that are available for our employees.

In 2023 our teams completed a total of 58 597 hours of training, with an average of 22.1 hours training per employee.

Internal and external training hours, by region

Region	Internal (h)	External (h)	Total (h)	% Total
Americas	37 488	11 577	49 064	83.7%
Europe & AP	4 865	4 668	9 533	16.3%
Grand Total	42 353	16 245	58 597	100.0%
	72.3%	27.7%		

This represents a decrease of 2.1% (3 422h) of training, when compared to 2022.

Although we observed a decrease in the internal training hours, our total hours of external training increased by 23%, when compared to 2022.

The Americas doubled the number of hours for external training vs 2022, which aligns with the higher turnover and new hires in this region.

Our Performance Management System not only outlines the agreed annual objectives but also identifies learning and development activities to enable employee's personal growth in current role and prepare them for future challenges.

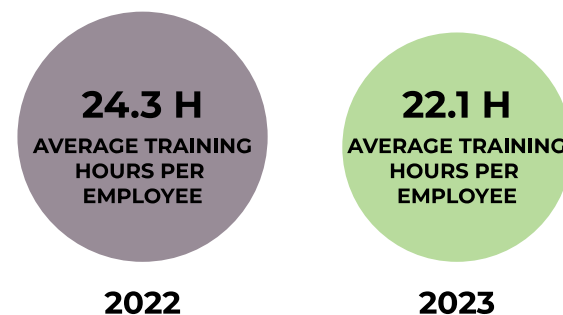

i Details by country can be consulted in Appendix 04.

HR METRICS

SHAPING CAREERS ALL THE WAY

Drive & focus

Personal development at Logoplaste is offered to everyone, all an employee needs to bring to the table is predisposition. All that are ready to learn and want to build a career in manufacturing, Logoplaste will provide training, hands on practice, and opportunities.

Different opportunities, plus our continued effort to improve employee experiences, shared knowledge, and career development are key to maintaining our talent pool.

In 2023 we had a total of 41 internal transfers, 6 more than in 2022.



41 Internal transfers



38

INSIDE
COUNTRY



3

BETWEEN
COUNTRIES

Note: *Internal Transfer is considered a change in position, with a change in location - either inside the same country or global mobility

HR METRICS

KEEPING RECORD, SO YOU CAN BE ON TRACK

Achieve, Performance Management System, is a fundamental process for Logoplaste. It is a key element for our employee's growth and development.

Achieve is implemented globally and there are two systems in place, for operational employees and another for technical, professional, managerial or executive employees.

Ongoing processes include check-in conversations, communicating and clarifying responsibilities, priorities and performance expectations, to ensure mutual understanding between manager and employee.

Achieve has 4 main stages



1 - PERFORMANCE
EXPECTATIONS
SETTING



2 - MID YEAR
REVIEW



3 - EMPLOYEE SELF
ASSESSMENT



4 - YEAR END
EVALUATION

HR METRICS

Completion of Achieve by region

Region	Total (%)
Americas	78.2%
Europe & AP	63.1%
Total	70.3%

The overall percentage of employees with performance evaluations across all countries is 70.3%.

There are noticeable country differences in the percentage of employees with performance evaluations.

High performers are countries like Brazil, Portugal, United States, Canada – with a high percentage and a large number of employees. Ireland, Italy, and Luxembourg, also have effective performance evaluations, although with a lower number of employees.

Countries with very low completion rates are Vietnam (1.2%) and Mexico (2.2%), followed by Poland (34.4%) and Spain (40.0%)

Remaining countries have high and very high completion rates.

 **Details by country can be consulted in Appendix 04.**

HR METRICS

EVERYONE HAS A VOICE. AND IT IS HEARD...

Logoplaste SpeakUp Channel is an important channel for our teams to raise concerns that may not be easily resolved through other means, or face-to-face.

Logoplaste promotes this whistleblowing platform through our internal channels, reminding employees that it is here for their wellbeing. The platform is accessible to all, in all countries and languages, through various means (phone, email, website), all the information is confidential and can be anonymous. Giving privacy to our teams is key.

The cases reported cover a range of concerns, including Discrimination, Employee Relations, Conflict of Interest, Workplace Violence/Threats, Policy Issues, and Substance Abuse. This diversity highlights the importance of having a whistleblowing hotline to address various types of misconduct and ensure a safe and ethical work environment.

A total of 12 cases were reported across different categories. While this represents a small fraction of the total workforce – 2 692 – each case was closed, as Logoplaste takes the whistleblower reports seriously, by investigating them and resolving issues (when applicable).

12 concerns and enquiries were reported in 2023.

There was a significant decrease in the average number of days

open for whistleblowing cases from 79 days last year to 26 days this year. Logoplaste has implemented more efficient processes for investigating and resolving whistleblowing cases, leading to quicker resolutions and outcomes.

Among the reported cases, 8 were submitted anonymously, while 4 were identified.

There is difficulty in investigating anonymous incidents. Logoplaste follows through and asks for more details, but anonymous whistleblowers rarely log in a second time to respond and help conclude the process. This tells us that, sometimes, the filled complaint may have been a spur of the moment, with high degree of emotion versus rationality, and once reported, the employee felt no need to follow-up.

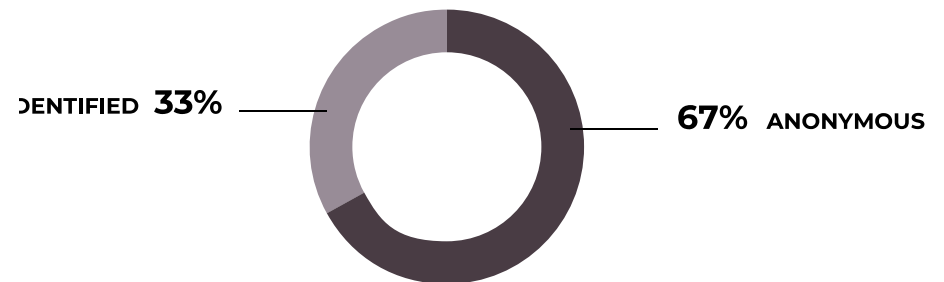

HR METRICS

Incidents reported through SpeakUp Channel

	Number of Cases	Cases reviewed by Logoplaste	Cases Still Open end 2023	Cases Closed
Accounting/Audit Irregularities				
Conflicts of Interest	1	1		1
Discrimination	3	3		3
Employee Relations	5	5		5
Falsification of Company Records				
Fraud				
Product Quality Concern				
Retaliation of Whistleblowers				
Substance Abuse				
Theft				
Workplace Violence/Threats	1	1		1
Customer Relations				
Policy Issues	1	1		1
Release of Proprietary information				
Safety Issues and Sanitation				
Sexual Harassment				
Substance Abuse	1	1		1
Wage/Hour Issues				
Total	12	12	0	12
		100%	0%	100%

■ HR METRICS

Employee Engagement Survey (EES)

Listening to what our team has to say is the only way to evaluate and measure how we are doing.

Confidential and anonymous, these surveys cover a broad set of topics, giving top management a clear vision of what needs to be done. Most importantly, these surveys give every employee a way to express their views and help shape Logoplaste into a better company.

The overall progress of the action plan implementation, by end of 2023 was at 82%, indicating a significant level of achievement in addressing the areas identified for improvement based on the engagement survey.

Safety and Fairness, Strategy Alignment, and Work/Life Balance have achieved 100% completion, showing a strong commitment to these aspects of employee well-being and organizational effectiveness.

Communication and Pride and Fulfilment also show high levels of completion at 90% and 89% respectively, reflecting efforts to enhance communication channels and foster a sense of pride and fulfillment among employees.

Compensation and Personal Development are areas where progress is above 79%, and with actions planned until end of 2024.





ETHICS & INTEGRITY

Ethics & Integrity are mirrored in all that we do

Ethics & Integrity is a material topic, resulting from our last Materiality Survey. This does not come as a surprise as these two characteristics are the cornerstones of Logoplaste's Values, Purpose, and Conduct.

The way we lead our business, be it in team motivation, negotiations, interactions with our business partners, liaising with our clients, dealing with suppliers, or reporting to our Board, Logoplaste has only one face, one side, one course of action, and it is anchored in transparency, respect, justice, and fairness.

■ ETHICS & INTEGRITY

Purpose

Logoplaste's purpose guides our daily efforts. It is rooted in our past while, at the same time, it clarifies our priorities. It is timeless and unselfish, serving those around us, be it our team, clients, communities, business partners. It shows how we create meticulously planned and executed packaging, delivered in a way that reduces CO₂ emissions and is a clear fit for circular economy.

■ CORPORATE VALUES

Our Corporate Values shape our actions, attitudes, behaviors, and our decisions.

- **PARTNERSHIP**
As a Wall to Wall manufacturer, we work within our customers' physical plants, supply chains, and cultures. We're more than partners. We're part of them.
- **QUALITY**
We strive to be the best in class and are committed to delivering the absolute best product possible.
- **INNOVATION**
Every Logoplaste employee is encouraged to innovate, solve problems, and create value, whether they work on a production line or in our Innovation Lab.
- **TEAMWORK**
We work and grow as a team, in a truly collaborative environment that includes our customers and everyone at Logoplaste.
- **SAFETY**
Safety comes first, always, no exceptions. We are constantly looking out for each other to create safe working environments—from our plants to our headquarters.
- **INTEGRITY**
We work in an open, honest environment that helps us to do the right thing. We treat our customers, partners, and colleagues with care, respect, and truthfulness.

■ ETHICS & INTEGRITY

■ CODE OF CONDUCT

Guide to what is expected from employees and from the company.

■ POLICIES

- **Anti-money laundering**
- **Anti-bribery & Anticorruption**

Training on these 2 policies is given on an annual basis to ensure there is a clear understanding of how we operate.

Logoplaste is fully committed to conducting its business with complete transparency.

■ EMPLOYEE'S VOICE

- **Employee Grievance Policies Policy**
- **Speak Up channel**
- **Ask the CEO**

■ DEI

Creating an improved experience for all stakeholders – this is the framework for our Diversity, Equity & Inclusion Program.

Logoplaste is committed to creating a workplace where different perspectives ensure a sustainable approach to long-term business challenges.

A place where you feel welcomed and cared for, where you can grow as a professional and as a person; where you have access to resources and knowledge; where respect and integrity guide all interactions and behaviors; and where your success depends on your performance and attitude.

■ OUR ROUTINE

Human Rights, Labor, Environment, and Anticorruption good practices are part of our routine.

■ SAFETY CULTURE

People always come first.

This is non-negotiable for us. But it's not just about keeping everyone out of harm's way, it's more than that:

1. Ensuring safety in our premises
2. Training our teams on how to perform tasks in a safe manner
3. 360° reporting & improving, finding new solutions to old routines
4. Wellbeing & Mental Health initiatives for all employees
5. Cyber security policies to protect employee as well as business information
6. Data privacy and confidentiality are key for a relationship based on trust

■ ETHICS & INTEGRITY

■ SUSTAINABLE PROCUREMENT

We are committed to the highest standards of ethical conduct, and we only work with those that share the same values and principles.

Logoplaste has a Sustainable Procurement Policy and a Supplier Code of Conduct, that show our suppliers what is expected of them, when conducting business: integrity, transparency and respect for universal human & labor rights, as well as for the environment.

We also take pride in helping to create a social and environmentally sustainable supply chain. This requires effort, commitment, and change, from all parties. It is our duty to help our suppliers reach this ambitious goal, by improving their results and way of doing business. To make things easy, we have developed a Supplier Guidance to support our suppliers in aligning their objectives with ours.

■ FULL LEGAL COMPLIANCE

With all local as well as international laws and regulations.



INNOVATION

Innovation is like flipping a coin, there is always one outcome

A new concept can succeed and be scaled to industrial production, replicated globally. Or it teaches us that this is not the way, and points to a different direction.

At Logoplaste we are not afraid of trial and error. This process propels us forward, breaking uncharted territory and rewarding us with innovative ideas to resolve all challenges.

■ INNOVATION

AI Design

Logoplaste Innovation Lab stands out with its unique blend of Design Thinking, Biomimicry, and generative AI, a pioneering approach to packaging design. This innovative synergy merges Nature's time-tested solutions with cutting-edge technology to create the most functional, aesthetically pleasing, and environmentally responsible packaging.

Our innovation process, powered by generative AI, learns from vast datasets, empowering us to create numerous design variations optimized for critical factors such as material efficiency, structural integrity, and environmental impact. By rapidly generating diverse options, generative AI allows our designers to explore a broader spectrum of possibilities, addressing complex challenges with unparalleled speed and precision.

We inform our packaging solutions by drawing inspiration from Nature's strategies. For instance, the biomechanics properties of plant leaves, which combine flexibility and strength, inspire us to design packaging that reduces material usage while maintaining durability. Similarly, the intricate structure of seashells, known for their layered strength and resilience, guides us in developing packaging that offers superior shock-absorbing protection.

The fusion of Biomimicry with generative AI harnesses the continuous multifunctional benefits of Nature's solutions. This integration enables us to analyze, synthesize, and emulate these biological models, incorporating them into our packaging designs with enhanced speed and efficiency.



■ INNOVATION

The potential of generative AI and Biomimicry in packaging design is vast. By leveraging the strengths of both, we create more innovative, functional, and sustainable packaging solutions.

As AI technology advances, our capabilities will further excel at deciphering complex biological data, leading to increasingly sophisticated and sustainable packaging solutions.

Join us as we lead the packaging industry toward a more enduring future in which packaging is as efficient, resilient, and harmonious as Nature.

■ INNOVATION

Designed to comply, while at the same time minimizing environmental impact

Tethered caps, all in one

Tethered caps are designed to remain attached to the bottle throughout the packaging's entire life cycle, making them more likely to be collected and recycled. This helps prevent plastic litter and is fully compliant with the EU 2019/904 Directive - Single-Use Plastics. This Directive stipulates that starting July 2024, plastic caps for all beverage bottles, with a capacity of up to 3 liters, may only be marketed if the cap remains attached to the bottle once opened.

This directive posed a challenge for the EU brands. Early on, in 2021, Logoplaste began the Tethered Caps Project, in partnership with Husky, so our clients could have the best solutions in terms of design, production, and consumer experience. In 2023 the last phase of the project was completed, and despite the increased complexity of the caps, Logoplaste presented a clever solution that reduces the amount of plastic by up to 10%. Our tethered caps not only prevent litter but also avoid CO₂ emissions.

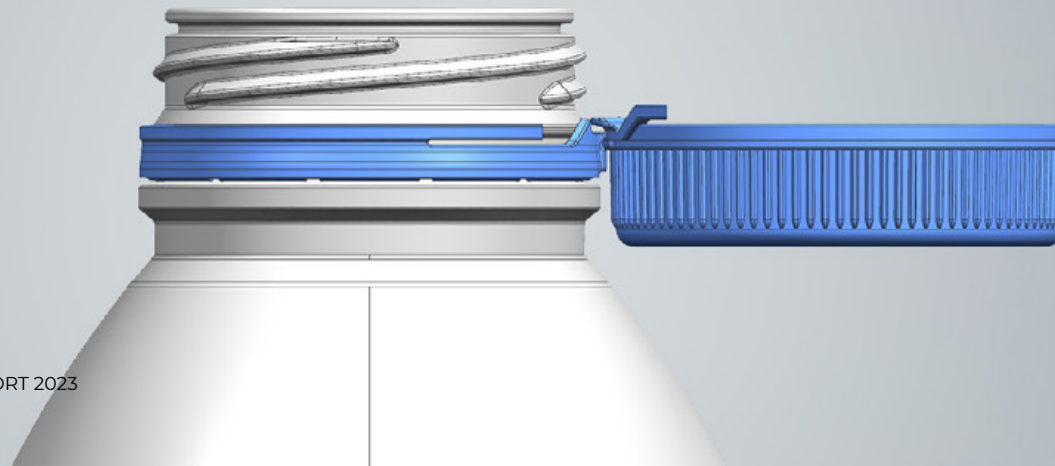

■ INNOVATION

High-performing alternative sources to fossil-based materials

On the right path

To create a more sustainable future, the Bionanopolys Project team developing large-scale, high-quality, biomaterials, exploring a potential alternative to fossil-based materials.

To drive adoption by industry and consumers, these new biomaterials must have functional properties for high-volume applications, as well as perform better than the current alternatives. Fossil-based raw materials are less expensive option, an impediment for biomaterials to enter the market successfully, therefore communication on environmental benefits will be key.

Within the Bionanopolys Project, Logoplaste was responsible for developing the rigid packaging solution

Bottles for food applications were developed and produced, via injection blow molding, using biodegradable biopolymers reinforced with nanoclays to improve barrier performance and product shelf-life.

Results on permeability and 100% compostability will be published in 2024. Stay tuned!





RECOGNITION

RECOGNITION



Logoplaste scored Gold in Ecovadis

We are in the overall top 5% and we are **in the top 2% of our industry.**

This is good news for us and **we are very be proud.** But we want to score higher next year...



SBTi - Science Based Target Initiative

Logoplaste submitted its targets for SBTi.

The bar has been set high, just as we like it.

At Logoplaste we are already the most effective plastic packaging producer, but we want to have better performance in reducing our carbon footprint and being more eco-friendly.



SCDP - Management Level

CDP Platform is a global disclosure system for investors, companies, cities, states, and regions to manage their environmental impacts. It aims to make environmental reporting and risk management a business norm, driving measurement, disclosure, insight, and effective mitigation strategies.

The world's economy looks to CDP as the standard of environmental reporting. At Logoplaste we are keeping consistent, and in 2023 are scores remained the same as in 2022:

- **CDP Climate Change B**
- **CDP Water Security B**

RECOGNITION

Recognition also comes from within

The Marcel de Botton Sustainability Awards were implemented in 2022 in honor of our beloved Founder Marcel de Botton.

In their second edition, the two awards recognize the plants with:

- Best **Performance** – best overall results
- Full **Commitment** – greatest improvement year over year

All Logoplaste plants are included and the competition is fierce. For 2023 the finalists were:

PERFORMANCE

- **Pittston** - USA
- **Pomezia** - Italy
- **Mealhada** - Portugal
- **Raposo Tavares** - Brazil
- **Thurrock** - UK

COMMITMENT

- **Cambrai** - France
- **Chicago** - USA
- **Elst** - Netherlands
- **Thurrock** - UK
- **Vilches** - Spain

And the winners, the two plants for their outstanding efforts:

- **Logoplaste Mealhada Performance Award**
- **Logoplaste Elst Commitment Award**

In addition to the recognition, Logoplaste provides each winner with 25.000€ to be donated to a local charity of their choice. While Mealhada and Elst led our efforts in 2023, our Sustainability Report shows that our commitment to a more sustainable future is global.





MORE ...

REPORT PROFILE

True to our purpose every step of the way

The 2023 Logoplaste Sustainability Report covers the period between January 1st 2023 and December 31st 2023 for all our worldwide operations, offices, and business partners where Logoplaste holds a majority stake. In 2023 the total number of sites considered in the report was 67.

Logoplaste's Sustainability Department is responsible for all presented content. This report is Logoplaste's primary source of annual disclosure on Environment, Social and Governance (ESG) performance.

For Logoplaste, being transparent with all our stakeholders about our sustainability ambitions and how we manage them, as well as integrate these priorities into our business, is key for our journey.

This report has been prepared in accordance with the Global Reporting Initiative (GRI) Standards. It has been externally audited. This report is only available in digital format, it is not printed.

© 2024 Logoplaste Consultores Técnicos S.A. All rights reserved. The report can be shared, in fact we encourage it, but content cannot be altered.





SUSTAINABILITY GOVERNANCE

Sustainability Governance

Our Sustainability Management Approach

Logoplaste's Sustainability Governance structure was created in 2018 and encompasses the Sustainability Board as well as the Sustainability Committee.

The Sustainability Board leads the way, setting the goals and targets, and is accountable for Logoplaste's sustainability results. It is responsible for defining Logoplaste's Sustainability Strategy, ensuring that Environmental, Social and Governance considerations are integrated, and objectives are met.

The Sustainability Committee is responsible for identifying risks and opportunities related to different areas within the company, defining actions to achieve Logoplaste's sustainability goals for the three pillars, driving initiatives and reporting to the Sustainability Board.

Logoplaste's CEO, Gerardo Chiaia, belongs both to the Sustainability Board and Logoplaste's Board. Sustainability updates are shared at every Board meeting.

SUSTAINABILITY GOVERNANCE

Meet our Sustainability Board



Filipe de Botton
CHAIRMAN



Gerardo Chiaia
CHIEF EXECUTIVE
OFFICER



Luis Almeida
CHIEF COMMERCIAL
OFFICER



Paulo Correia
CHIEF TECHNOLOGY
OFFICER

Meet our Sustainability Committee



Benoit Jeanjot
SENIOR VP OPERATIONS



Conceição Menezes
CHIEF DIGITAL OFFICER



Kevin Morgan
GLOBAL EHS DIRECTOR



Neil Parsons
EHS DIRECTOR, UK, EU &
AP



**Maria Eugenia
Zacarias**
RAW MATERIAL
MANAGER, LOGOPLASTE
INNOVATION LAB



Vera Pires
CORPORATE HR
MANAGER

MATERIALITY ASSESSMENT

A report based on research

We did our homework and followed every protocol

As part of Logoplaste's sustainability reporting process we performed our second Materiality Assessment in the last quarter of 2021 to update environmental, social, and economic topics most relevant to our stakeholders.

Stakeholders were identified based on how much they influence our business model and operations. These include Employees, Sustainability Board and Committee, Customers, Suppliers, Local Communities*, Regulators & Associations.

* The relevancy of topics for the local communities was evaluated through regulators and associations

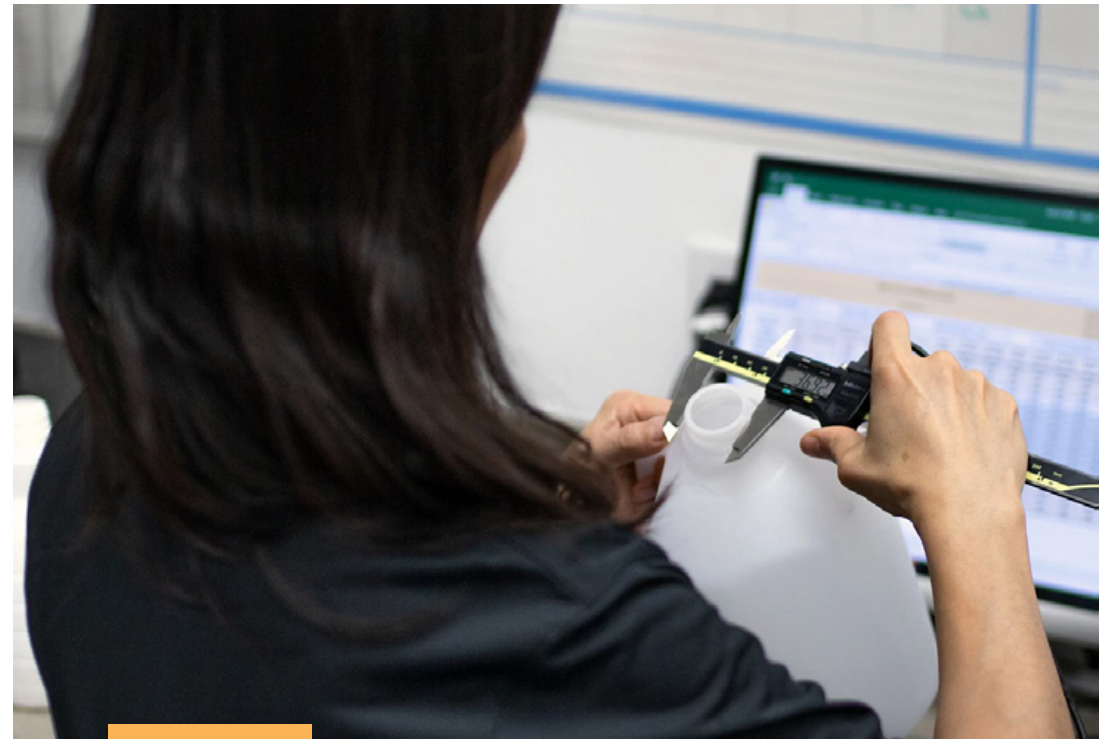

■ MATERIALITY ASSESSMENT

By understanding our stakeholders' priorities and concerns, we can identify associated risks, as well as business opportunities, that affect the creation of value or impact our business

1
We conducted a benchmark to identify the potential material topics. Our main sources were:

- The Global Reporting Initiative (GRI) standard
- Sustainability reports published by peers and customers
- Sustainability rating systems (CDP and Ecovadis), stakeholders' inputs (from meetings, conferences, discussions)
- Sustainability topics in the media
- New and emerging legislation and policies
- The previous Logoplaste materiality assessment (2019).

2
Our Sustainability Board defined 18 relevant topics to be surveyed, as well as the thresholds and weights to be considered for the materiality matrix

- Ethics & Integrity
- Performance Compliance
- Materials & Product Characteristics
- Energy & GHG Emissions
- Water Management
- Operational Waste
- Data Privacy & Cybersecurity
- Employee Well-Being
- Human Rights & Labor Practices
- Inclusion, Diversity & Equal Opportunities
- Occupational Health & Safety
- Local Communities
- Compliance
- Sustainable Procurement
- Innovation & Development
- Wall to wall (W2W) Business Approach
- Value-Chain Partnerships
- Circularity & Education

3
An online sustainability survey was sent to 281 stakeholders, with a response rate of 80%.

4
Results were presented in a materiality matrix, reviewed and approved by the Sustainability Board. The resulting material topics were:

- Innovation & Development
- Ethics & Integrity
- Energy & GHG Emissions
- Materials & Product Characteristics
- Circularity & Education
- Human Rights & Labor Practices
- Compliance
- Operational Waste

For 2023 we reviewed the material topics based on updated information and we considered them still relevant.

■ STAKEHOLDER ENGAGEMENT

Working together

Engagement needs to be 2-way, otherwise we are just talking, not communicating.

Engaging with stakeholders means creating an environment where all parties can share, learn, align, and reach the same goals. The more we communicate and involve our key partners, the more success we will have in delivering sustainable products, reaching our commitments, and meeting targets.

Working together also means we work with local, regional and global business partners, big and small. When engaging in a new project, we must look at all the variables, not just cost, or investment, but social and environmental impact, logistics, CO2 emissions, and fairness across the board. The decision might not be the best financially, but for us at Logoplaste, the entire business-ecosystem needs to be taken into account.



STAKEHOLDER ENGAGEMENT

Our channels & actions

CUSTOMERS

- Website
- LinkedIn
- Sustainability Report
- Sustainability Survey
- Ecovadis
- CDP

COMMUNITIES

- Internship Programs
- Financial Support
- Employee Volunteering Initiatives
- Student Support and Engagement
- Website
- LinkedIn
- Job Opportunities

SUPPLIERS

- Policies
- Code Of Conduct
- Supplier Guidance
- Website
- LinkedIn
- Sustainability Report
- Sustainability Survey
- Ecovadis
- CDP
- Meetings

REGULATORS AND ASSOCIATIONS

- Website
- LinkedIn
- Website LinkedIn
- Sustainability Report
- Sustainability Survey
- Ecovadis
- CDP
- Meetings

EMPLOYEES, SUSTAINABILITY BOARD & SUSTAINABILITY COMMITTEE

- ENGAGE: Employee Engagement Survey
- ACHIEVE: Performance Management System – Evaluation
- Speak Up
- CEO Quarterly Overviews
- CEO Global Broadcasts
- Ask The CEO
- Intranet
- On the Wall – internal social media platform
- Website
- LinkedIn
- Corporate Television
- Posters
- Branding
- Global and targeted Emails
- Sharing Sessions
- Ecovadis
- CDP
- Code Of Conduct
- Sustainability Report
- Sustainability Survey
- Newsletter

SUSTAINABLE DEVELOPMENT GOALS (SDGS)

The United Nations Sustainable Development Goals - global objectives for people and the planet.

The 17 Sustainable Development Goals (SDGs) issued by the United Nations lay out a path to help end poverty, fight inequalities, and tackle climate change.

Achieving these ambitions by 2030 is a joint effort by all. Businesses play a fundamental role in the process alongside governments, institutions, and individuals. As a global society, we all need to make an unprecedented effort to meet the Sustainable Development Goals. This is something we cannot reach by ourselves. Isolated efforts will not make an impact.

Back in 2021, Logoplaste mapped its business activities against the SDGs and identified 6 topics that align with our business model in which we can make significant contributions. Having the company's materiality SDG's clearly defined helps guide our sustainability strategy, so we can mitigate negative impacts and focus on areas where we deliver positive change.



■ SUSTAINABLE DEVELOPMENT GOALS (SDGS)

Logoplaste's Material SDGs



■ **ENSURE AVAILABILITY AND SUSTAINABLE MANAGEMENT OF WATER AND SANITATION FOR ALL**

- Global water policy
- Pollution prevention policy
- WASH* services to all employees
- Effective water management
- Water reduction initiatives
- Water awareness campaigns
- Water risk mapping
- Operation Clean Sweep (OCS)

* Water, Sanitation and Hygiene



■ **ENSURE ACCESS TO AFFORDABLE, RELIABLE, SUSTAINABLE AND MODERN ENERGY FOR ALL**

- Effective energy management
- Energy efficiency initiatives
- Energy awareness campaigns
- Renewable energy purchases
- Renewable energy production
- Working with clients on clean energy



■ **BUILD RESILIENT INFRASTRUCTURE, PROMOTE INCLUSIVE AND SUSTAINABLE INDUSTRIALIZATION AND FOSTER INNOVATION**

- Wall to wall business model
- Investment in R&D capabilities
- Design for recyclability & biomimicry
- Recycling infrastructure
- Collaboration in cutting-edge projects

■ SUSTAINABLE DEVELOPMENT GOALS (SDGS)



■ ENSURE SUSTAINABLE CONSUMPTION AND PRODUCTION PATTERNS

- Wall to wall business model
- Lightweight/right-weight programs
- Design for recyclability & biomimicry
- Use of recycled raw materials
- Recyclclass Exclusive Auditor Center for Recyclability Certifications
- Waste management policy
- Waste management and reduction initiatives
- Sustainable procurement policy



■ TAKE URGENT ACTION TO COMBAT CLIMATE CHANGE AND ITS IMPACTS

- Wall to wall business model
- Operational GHG emissions reduction target (absolute & intensity)
- Operational GHG emissions intensity reduction target
- Commitment to set SBTs (near-term & long-term), aligned with 1.5°C
- Transition to renewable energy
- Global quality, environmental, health & safety policy
- Pollution prevention policy
- Waste management policy
- Lands right policy
- Sustainable procurement policy



■ CONSERVE AND SUSTAINABLY USE THE OCEANS, SEAS, AND MARINE RESOURCES

- Global water policy
- Pollution prevention policy
- Waste management policy
- Water awareness campaigns
- Waste management and reduction initiatives
- Operation Clean Sweep (OCS)
- Incorporation of ocean-bound plastic

CERTIFICATIONS AND MEMBERSHIPS

CERTIFICATIONS	
ISCC PLUS International Sustainability and Carbon Certification	Estarreja, Guadalajara, Leeds, Dumfries, Vienne
Quality ISO 9001	Brazil Office, France/Belgium Office, Libramont, Lons, Cambrai, Pomezia, Mealhada, MasterChem Logoplaste, Ecoibéria
Food Safety BRC-British Retail Consortium	Thurrock, Leeds, Coleford, Dumfries, Andujar, Brenes, Guadalajara, Tenerife, Vilches, Araras I, Araras II
Food Safety FSSC 22000	Abrantes, Barreiro, Castelo Branco, Castelo de Vide, Estarreja, Guarda, Ladeira, Oliveira de Azeméis, Pedras Salgadas, Mealhada, Vacariça, Elst, Chicago, Fort Worth, Joliet, Minster, Plainfield, Syracuse, Pittston, Cambrai, Lons, Vienne, France/Belgium Office, Zoetermeer, Vaudreil
Food Safety ISO 22000	Vietnam
Environmental Management ISO 14001	MasterChem Logoplaste, Ecoibéria, Araras I, Pará de Minas
Health & Safety ISO 45001	Coleford, Pomezia, Mealhada, Leeds, Guadalajara, Thurrock, Dumfries, Vietnam, Araras I, Plainfield, Tabler Station, Elst, Leeds, Edmonton, Pará de Minas
Health & Safety ISO 15378	Tabler Station; MasterChem Logoplaste
Management of hygiene in the production of packaging for foodstuffs ISO 15593	MasterChem Logoplaste
LEED Certification - Silver	Tabler Station
European Certification of Plastics Recycling EuCertPlast	Ecoibéria
Operation Clean Sweep	Lons, Vienne, Cambrai
SEDEX ETHICAL TRADING MEMBER	Portugal Office, Araras I, Raposo Tavares, Araras II, Amparo, Coleford, Leeds, Dumfries, MasterChem Logoplaste, Estarreja, Guarda, Castelo Branco, Elst, Pudliszki, Chicago, Fort Worth, Minster, Plainfield, Racine, Vaudreil

CERTIFICATIONS AND MEMBERSHIPS

MEMBERSHIPS/ENDORSEMENTS	
Global	<ul style="list-style-type: none"> • Ellen MacArthur Foundation – New Plastics Economy Global Commitment • UN Global Compact – 10 Principles • SBTi - Science Based Target Initiative
Spain	<ul style="list-style-type: none"> • ANAIP - Asociación Española de Industriales de Plásticos • AIMPLAS – Instituto Tecnológico del Plástico
Portugal	<ul style="list-style-type: none"> • APIP – Associação Portuguesa da Indústria de Plásticos • CNE – Centro Nacional de Embalagens • PLASTVAL
Europe	<ul style="list-style-type: none"> • EuPC – Founding member • PETCore – Founding member
Brazil	<ul style="list-style-type: none"> • Rede de Cooperação para o Plástico • ABIPLAST - Associação Brasileira da Indústria do Plástico • Acordo Setorial de Embalagens em Geral • ABRE – Associação Brasileira de Embalagem • ABRH - Associação Brasileira de Recursos Humanos
UK	<ul style="list-style-type: none"> • BBI – British Bottler’s Institute • BPF – British Plastics Federation • British Safety Council • British Soft Drinks Association • The Packaging Federation • RECOUP - Recycling of Used Plastics Ltd
France	<ul style="list-style-type: none"> • ELIPSO • Plastalliance
Belgium	<ul style="list-style-type: none"> • AGORIA



GRI CONTENT INDEX

Logoplaste has reported in accordance with the GRI Standards for the period between January 1st to December 31st, 2023

* Material Topic

DISCLOSURE NUMBER GENERAL STANDARD DISCLOSURE GRI 2 - GENERAL DISCLOSURES 2021	DESCRIPTION	CROSS-REFERENCE (HYPERLINKS) OR DIRECT ANSWER
2-1	Organizational details	Organizational details AT A GLANCE - Who we are? MORE - Report Profile Location of headquarters: 412F, Route d'Esch L-2086, Luxembourg Ownership and legal form: Logoplaste Group (Logoplaste) is a private company incorporated in Luxembourg Find out where we are Scale of the organization: Logoplaste Group has Total Assets of 1 890 Million Euros and Equity of 363 Million Euros. Logoplaste's net sales for 2023 were 864 Million Euros

■ GRI CONTENT INDEX

2-2	Entities included in the organization's sustainability report	MORE - Report Profile Find out where we are
2-3	Reporting period, frequency and contact point	MORE - Report Profile Reporting period: 1st January to 31st December 2023; Frequency: annual; Date of Report: June 2024; Contact Point: Luis Almeida (luis.almeida@logoplaste.com)
2-4	Restatements of information	Data reported in 2019, 2020 and 2021 for GHG emissions and water were reviewed based on new available information and updated methodologies
2-5	External assurance	MORE - Report Profile This report was verified by external entities
2-6	Activities, value chain and other business relationships	AT A GLANCE - Who we are? ENVIRONMENT - Circularity PEOPLE - Ethics & Integrity MORE - Stakeholder Engagement INNOVATION
2-7	Employees	HOME - Exceeding expectations AT A GLANCE - Who we are? PEOPLE - HR metrics
2-8	Workers who are not employees	AT A GLANCE - Who we are? PEOPLE - HR metrics
2-9	Nomination and selection of the highest governance body	HOME - Chairman and CEO Statements MORE - Sustainability Governance PEOPLE - HR metrics Logoplaste Executive Team

■ GRI CONTENT INDEX

2-10	Nomination and selection of the highest governance body	HOME - Chairman and CEO Statements MORE - Sustainability Governance Logoplaste Executive Team
2-11	Chair of the highest governance body	HOME - Chairman and CEO Statements MORE - Sustainability Governance Logoplaste Executive Team
2-12	Role of the highest governance body in overseeing the management of impacts	HOME - Chairman and CEO Statements MORE - Sustainability Governance MORE - Stakeholder Engagement Logoplaste Executive Team
2-13	Delegation of responsibility for managing impacts	HOME - Chairman and CEO Statements MORE - Sustainability Governance Logoplaste Executive Team
2-14	Role of the highest governance body in overseeing the sustainability reporting	HOME - Chairman and CEO Statements MORE - Sustainability Governance Logoplaste Executive Team
2-15	Conflict of interests	HOME - Chairman and CEO Statements MORE - Sustainability Governance PEOPLE - HR metrics PEOPLE - Ethics & Integrity Code of Conduct Code of Conduct for Suppliers and Contractors

■ GRI CONTENT INDEX

		PEOPLE - Engagement PEOPLE - HR metrics SAFETY - Initiatives MORE - Stakeholder Engagement Code of Conduct Code of Conduct for Suppliers and Contractors
2-16	Communication of critical concerns	
2-17	Collective knowledge of the highest governance body	HOME - Chairman and CEO Statements MORE - Sustainability Governance PEOPLE - Ethics & Integrity
2-18	Evaluation of the performance of the highest governance body	PEOPLE - HR metrics
2-19	Remuneration policies	PEOPLE - Engagement PEOPLE - HR metrics PEOPLE - Ethics & Integrity Not all disclosures are reported due to confidentiality constraints
2-20	Process to determine remuneration	PEOPLE - Engagement PEOPLE - HR metrics PEOPLE - Ethics & Integrity Not all disclosures are reported due to confidentiality constraints
2-21	Annual total compensation ratio	PEOPLE - Engagement PEOPLE - HR metrics PEOPLE - Ethics & Integrity Not all disclosures are reported due to confidentiality constraints
2-22	Statement on sustainable development strategy	HOME - Chairman and CEO Statements

GRI CONTENT INDEX

<p>2-23</p>	<p>Policy Commitments</p>	<p>At A GLANCE - Sustainability PEOPLE - Engagement PEOPLE - Ethics & Integrity SAFETY - Always first SAFETY - Initiatives Code of Conduct Sustainable Procurement Policy Global EHS & Quality Policy Global Water Policy Global Waste Policy Land Rights Policy</p>
<p>2-24</p>	<p>Embedding policy commitments</p>	<p>AT A GLANCE - Who we are At A GLANCE - Sustainability ENVIRONMENT - Positive impact PEOPLE - Engagement PEOPLE - Ethics & Integrity SAFETY - Always first SAFETY - Initiatives INNOVATION Details of how Logoplaste embodies its policy commitments are spread throughout the report for relevant material topics</p>
<p>2-25</p>	<p>Process to remediate negative impacts</p>	<p>PEOPLE - Engagement PEOPLE - HR metrics PEOPLE - Ethics & Integrity MORE - Stakeholder Engagement MORE - SDGs</p>

■ GRI CONTENT INDEX

		PEOPLE - Engagement PEOPLE - HR metrics PEOPLE - Ethics & Integrity SAFETY - Always first MORE - Materiality Assessment MORE - Stakeholder Engagement Code of Conduct Sustainable Procurement Policy Code of Conduct for Suppliers and Contractors
2-26	Mechanisms for seeking advice and raising concerns	
2-27	Compliance with laws and regulations	PEOPLE - Ethics & Integrity ENVIRONMENT - Positive impact SAFETY - Always first
2-28	Membership associations	MORE - Certifications and Memberships
2-29	Approach to stakeholder engagement	MORE - Materiality Assessment
2-30	Collective bargaining agreements	PEOPLE - HR metrics
GRI 3 - Material Topics		
3-1	Process to determine material topics	MORE - Materiality Assessment
3-2	List of material topics	MORE - Materiality Assessment
200 Economic		
205: Anti-corruption*		
3-3	Management of material topics	Logoplaste material topics have been identified through the auscultation of stakeholders combined with the internal perspective of the company: MORE - Materiality Assessment PEOPLE - Ethics & Integrity

GRI CONTENT INDEX

205-3	Confirmed incidents of corruption and actions taken	No incidents of corruption in the reporting cycle. PEOPLE - HR metrics
206: Anti-competitive behavior*		
3-3	Management of material topics	Logoplaste material topics have been identified through the auscultation of stakeholders combined with the internal perspective of the company: MORE - Materiality Assessment PEOPLE - Ethics & Integrity
206-1	Legal actions for anti-competitive behavior, anti-trust, and monopoly practices	No legal actions for anti-competitive behavior, anti-trust, and monopoly practices in the reporting cycle.
300 Environmental		
301: Materials*		
3-3	Management of material topics	Logoplaste material topics have been identified through the auscultation of stakeholders combined with the internal perspective of the company: MORE - Materiality Assessment ENVIRONMENT - Positive impact ENVIRONMENT - Materials & product characteristics
301-2	Recycled input materials used	HOME - Exceeding expectations ENVIRONMENT - Positive impact ENVIRONMENT - Materials & product characteristics
302: Energy*		
3-3	Management of material topics	Logoplaste material topics have been identified through the auscultation of stakeholders combined with the internal perspective of the company: MORE - Materiality Assessment ENVIRONMENT - Positive impact ENVIRONMENT - Energy
302-1	Energy consumption within the organization	ENVIRONMENT - Positive impact ENVIRONMENT - Energy

■ GRI CONTENT INDEX

303: Water		
303-1	Interactions with water as a shared resource	ENVIRONMENT - Water
303-2	Management of water discharge-related impacts	ENVIRONMENT - Water
303-3	Water withdrawal	ENVIRONMENT - Water
305: Emissions*		
3-3	Management of material topics	Logoplaste material topics have been identified through the auscultation of stakeholders combined with the internal perspective of the company: MORE - Materiality Assessment ENVIRONMENT - Positive impact ENVIRONMENT - Greenhouse gas emissions
305-1	Direct (Scope 1) GHG emissions	ENVIRONMENT - Greenhouse gas emissions
305-2	Energy indirect (Scope 2) GHG emissions	ENVIRONMENT - Greenhouse gas emissions
305-3	Other indirect (Scope 3) GHG emissions	ENVIRONMENT - Greenhouse gas emissions
305-4	GHG emissions intensity	ENVIRONMENT - Greenhouse gas emissions
306: Waste*		
3-3	Management of material topics	Logoplaste material topics have been identified through the auscultation of stakeholders combined with the internal perspective of the company: MORE - Materiality Assessment ENVIRONMENT - Positive impact ENVIRONMENT - Waste
306-1	Waste generation and significant waste-related impacts	ENVIRONMENT - Waste
306-2	Management of significant waste-related impacts	ENVIRONMENT - Waste
306-3	Waste generated	ENVIRONMENT - Waste

■ GRI CONTENT INDEX

306-4	Waste diverted from disposal	ENVIRONMENT - Waste
306-5	Waste directed to disposal	ENVIRONMENT - Waste
307: Environmental Compliance*		
3-3	Management of material topics	Logoplaste material topics have been identified through the auscultation of stakeholders combined with the internal perspective of the company: MORE - Materiality Assessment Code of Conduct
307-1	Non-compliance with environmental laws and regulations	There were no fines and non-monetary sanctions for non-compliance with environmental laws and regulations in the reporting period.
401-1	New employee hires and employee turnover	PEOPLE - HR metrics
401-2	Benefits provided to full-time employees that are not provided to temporary or part-time employees	PEOPLE - Engagement
403: Occupational health and safety		
403-1	Occupational health and safety management system	SAFETY - Always first SAFETY - Initiatives
403-2	Hazard identification, risk assessment, and incident investigation	SAFETY - Always first SAFETY - Initiatives
403-3	Occupational health services	SAFETY - Always first
403-4	Worker participation, consultation, and communication on occupational health and safety	SAFETY - Always first SAFETY - Initiatives
403-5	Worker training on occupational health and safety	SAFETY - Always first SAFETY - Initiatives
403-6	Promotion of worker health	SAFETY - Always first SAFETY - Initiatives

■ GRI CONTENT INDEX

403-7	Prevention and mitigation of occupational health and safety impacts directly linked by business relationships	SAFETY - Always first SAFETY - Initiatives
403-8	Workers covered by an occupational health and safety management system	SAFETY - Always first SAFETY - Initiatives
403-9	Work-related injuries	SAFETY - OHS Metrics
403-10	Work-related ill health	SAFETY - OHS Metrics
404: Training and education		
404-1	Average hours of training per year per employee	PEOPLE - HR metrics
405: Diversity and equal opportunity		
405-1	Diversity of governance bodies and employees	HOME - Exceeding expectations AT A GLANCE - Who we are? PEOPLE - HR metrics
406: Non-discrimination*		
3-3	Management of material topics	Logoplaste material topics have been identified through the auscultation of stakeholders combined with the internal perspective of the company: MORE - Materiality Assessment Code of Conduct
406-1	Incidents of discrimination and corrective actions taken	PEOPLE - HR metrics
407: Freedom of association and collective bargaining*		
3-3	Management of material topics	Logoplaste material topics have been identified through the auscultation of stakeholders combined with the internal perspective of the company: MORE - Materiality Assessment Code of Conduct Code of Conduct for Suppliers and Contractors

GRI CONTENT INDEX

407-1

Operations and suppliers in which the right to freedom of association and collective bargaining may be at risk

Not identified operations and suppliers in which the right to freedom of association and collective bargaining may be at risk. See also:

- [AT A GLANCE - Who we are?](#)
- [PEOPLE - Ethics & Integrity](#)
- [PEOPLE - HR metrics](#)

408: Child Labor*

3-3

Management of material topics

Logoplaste material topics have been identified through the auscultation of stakeholders combined with the internal perspective of the company:

- [MORE - Materiality Assessment](#)
- [Code of Conduct](#)
- [Code of Conduct for Suppliers and Contractors](#)

408-1

Operations and suppliers at significant risk for incidents of child labor

Not identified operations and suppliers at significant risk for incidents of child labor. See also:

- [AT A GLANCE - Who we are?](#)
- [PEOPLE - Ethics & Integrity](#)
- [PEOPLE - HR metrics](#)

409: Forced or Compulsory Labor*

3-3

Management of material topics

Logoplaste material topics have been identified through the auscultation of stakeholders combined with the internal perspective of the company:

- [MORE - Materiality Assessment](#)
- [Code of Conduct](#)
- [Code of Conduct for Suppliers and Contractors](#)

409-1

Operations and suppliers at significant risk for incidents of forced and compulsory labor

Not identified operations and suppliers at significant risk for incidents of forced and compulsory labor. See also:

- [AT A GLANCE - Who we are?](#)
- [PEOPLE - Ethics & Integrity](#)
- [PEOPLE - HR metrics](#)

GRI CONTENT INDEX

412: Human Rights Assessment*

<p>3-3</p>	<p>Management of material topics</p>	<p>Logoplaste material topics have been identified through the auscultation of stakeholders combined with the internal perspective of the company: MORE - Materiality Assessment PEOPLE - Ethics & Integrity Code of Conduct</p>
<p>412-2</p>	<p>Employee training on human rights policies or procedures</p>	<p>PEOPLE - Ethics & Integrity Code of Conduct</p>

419: Socioeconomic compliance*

<p>3-3</p>	<p>Management of material topics</p>	<p>Logoplaste material topics have been identified through the auscultation of stakeholders combined with the internal perspective of the company: MORE - Materiality Assessment Code of Conduct</p>
<p>419-1</p>	<p>Non-compliance with laws and regulations in the social and economic area</p>	<p>There were no fines and no non-monetary sanctions for non-compliance with laws and regulations in the social and economic area in the reporting cycle.</p>

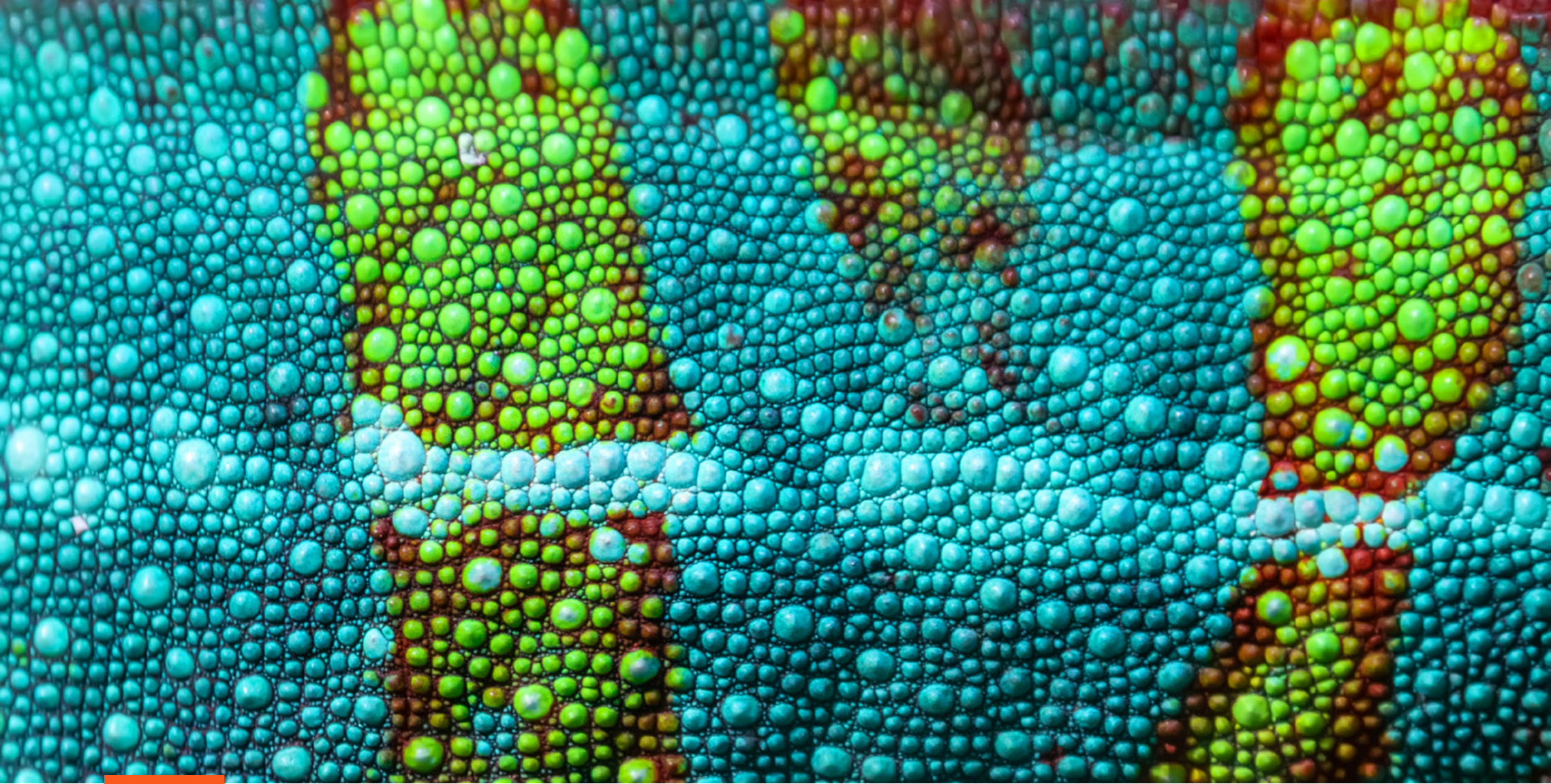

APPENDICES

APPENDIX 01

Energy consumption table and the methodological process

Detail of Energy Consumption within Logoplaste

	2019	2020	2021	2022	2023	2023 vs 2022 (%)	2023 vs 2019 (%)
LOGOPLASTE PLANTS	Energy (GJ)	Energy (GJ)	Energy (GJ)	Energy (GJ)	Energy (GJ)		
Total electricity purchased for consumption:	1 153 083	1 327 191	1 289 582	1 374 852	1 435 839	4%	25%
Electrical grid - brown electricity	969 570	1 096 618	908 619	863 361	826 671	-4%	-15%
Electrical grid - 100% green electricity	78 680	127 148	276 787	400 851	493 691	23%	527%
CHP systems (natural gas)	103 123	101 766	102 762	107 729	112 099	4%	9%
Photovoltaic panels	1 711	1 660	1 414	2 913	3 378	16%	97%
Total electricity self-generated and self-consumed from renewable sources:	0	2 263	2 894	3 688	6 238	69%	
Photovoltaic panels	0	2 263	2 894	3 688	6 238	69%	
Total fuel consumption from non-renewable sources:	30 675	38 066	35 797	52 622	54 007	47%	76%
Natural gas - heating, machinery	26 808	25 904	23 865	39 957	42 157	6%	57%
LPG - forklifts	2 502	3 422	3 914	3 928	3 652	-7%	46%
Red diesel consumption - forklifts	542	114	83	359	36	-90%	-93%
Diesel - company trucks	824	8598	7912	8 342	8 121	-3%	886%
Petrol	0	29	23	36	41	14%	
TOTAL	1 183 758	1 367 521	1 328 274	1 431 162	1 496 084	5%	26%

*GJ - Gigajoules

APPENDIX 01

Detail of Energy Consumption within Logoplaste

Energy Consumption within Logoplaste

	2019	2020	2021	2022	2023	2023 vs 2022 (%)	2023 vs 2019 (%)
CORPORATE OFFICES	Energy (GJ)	Energy (GJ)	Energy (GJ)	Energy (GJ)	Energy (GJ)		
Total electricity consumption:	8 615	4 307	10 256	13 690	11 343	-17%	59%
Electrical Grid - brown electricity	8 615	4 307	10 256	10 542	6 021	-43%	22%
Electrical Grid - 100% green electricity	0	0	0	3 148	5 322	69%	
Total electricity self-generated from renewable sources:	508	494	462	324	342	6%	-36%
Photovoltaic panels	508	494	462	324	342	6%	-36%
Total electricity sold from renewable sources:	508	494	462	324	342	6%	-36%
Photovoltaic panels	508	494	462	324	342	6%	-36%
Total fuel consumption from non-renewable sources:	9 444	7 698	7 595	9 712	11 384	17%	3%
Diesel for company cars	7 684	5 648	5 105	5 927	6 161	4%	-23%
Petrol for company cars	1 760	2 051	2 490	3 785	5 223	38%	115%
TOTAL	18 059	12 006	17 851	23 402	22 727	-3%	26%

*GJ - Gigajoules

APPENDIX 01

Detail of Energy Consumption within Logoplaste

Total (Logoplaste Plants and Corporate Offices)

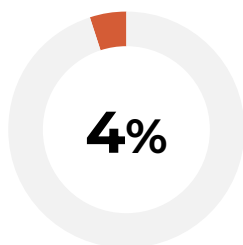
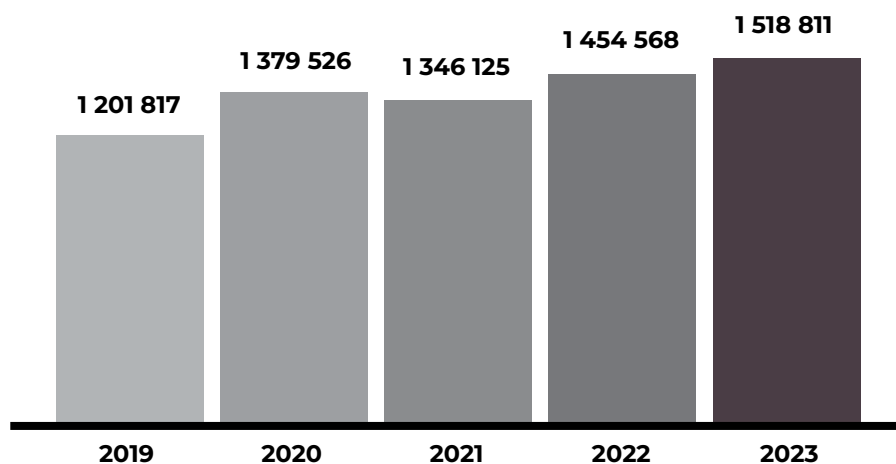

2023 vs 2022 (%)

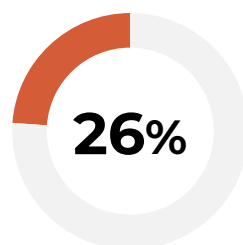

2023 vs 2019 (%)

In plants where energy data was not available, data was extrapolated from similar plants (same technology and raw materials) based on raw material consumption. For corporate offices where data was not available, data was extrapolated from other offices based on number of employees.

Some plants use steam provided by the customer, but consumption is not available as there are no meters installed. Based on information provided by the customers we estimated that steam represents less than 0.4% of the total electricity consumption.

The conversion factor used to convert kWh to GJ is 0.0036, as defined by the International Energy Agency (IEA). The formula:

$$\text{Energy (GJ)} = \text{Consumption (tons/year)} * \text{LHV (MJ/kg)}$$

was used to convert fuel consumption to GJ. We used the Density and LHV (low heating value) values available in DEFRA UK conversion factors database – Fuel properties. As fuel consumption represents a small percentage of our energy consumption, we didn't apply country specific conversion factors as the impact on the final results wouldn't be significant.

APPENDIX 02

Details of scope 1 and scope 2

Sources of scope 1 emissions, corresponding consumptions and CO₂e emissions, from 2019 to 2023.

		2019			2020			2021			2022			2023		
SCOPE 1	Unit	Consumption	Emissions (Tons CO ₂ e)	%	Consumption	Emissions (Tons CO ₂ e)	%	Consumption	Emissions (Tons CO ₂ e)	%	Consumption	Emissions (Tons CO ₂ e)	%	Consumption	Emissions (Tons CO ₂ e)	%
Natural Gas	m ³	748 956	1 521	36.7%	723 405	1 463	32.7%	662 482	1 339	43.5%	1 119 004	2 256	52.8%	1 157 644	2 360	55.1%
LPG	kg	54 499	160	3.9%	74 485	219	4.9%	85 189	250	8.1%	85 501	251	5.9%	79 463	233	5.4%
Red Diesel	L	14 899	41	1.0%	3 127	9	0.2%	2 280	6	0.2%	9 982	28	0.6%	1 001	3	0.1%
Petrol	L	0	0	0.0%	892	2	0.0%	707	2	0.1%	1 102	2	0.1%	1 282	3	0.1%
Diesel - Company Cars	L	236 980	615	14.9%	397 402	1 012	22.7%	362 224	910	29.6%	397 177	1 016	23.8%	402 550	1 030	24.0%
Petrol - Company Cars	L	54 453	120	2.9%	63 498	138	3.1%	76 389	168	5.4%	116 508	252	5.9%	163 539	353	8.3%
Refrigeration Gases Leakages	kg	809	1 682	40.6%	829	1 625	36.4%	213	404	13.1%	266	464	10.9%	167	300	7.0%
TOTAL		-	4 139	100%	-	4 468	100%	-	3 079	100%	-	4 269	100%	-	4 282	100%

APPENDIX 02

Details of scope 1 and scope 2

Although through the report we refer only to scope 2 market-based emissions we also calculate scope 2 location-based emissions, as shown in the following table:

Scope 2 location-based and scope 2 market-based

Year	Emissions (Tons CO ₂ e)	
	Scope 2: Location-Based	Scope 2: Market-Based
2019	99 588	100 070
2020	126 505	122 791
2021	130 970	94 007
2022	128 461	89 444
2023	142 514	84 778



APPENDIX 03

GHG emissions methodology and details

SCOPE 1 AND SCOPE 2 GHG EMISSIONS

We report our greenhouse gas (GHG) emissions according to the GHG Protocol developed by the World Resources Institute (WRI) and the World Business Council on Sustainable Development (WBCSD).

Emissions reported are all from entities over which Logoplaste has operational control.

Global warming potential (GWP) values for a 100-year time horizon are from 4th assessment report (AR4).

Scope 1 and 2 GHG emissions are calculated based on the Greenhouse Gas Protocol: Corporate Accounting and Reporting Standard (Revised Edition). Carbon dioxide (CO₂) is the predominant gas included in the calculation of Scope 1 and 2 emissions, but emissions factors may also include small amounts of methane (CH₄) and nitrous oxide (N₂O). Sulfur hexafluoride SF₆, used in the electrical industry as a gaseous dielectric medium for high-voltage circuit breakers, switchgear, and other electrical equipment, is also considered. As Logoplaste uses refrigerants, HFC's are also included.

Emissions factors for Scope 1 are from Greenhouse gas reporting: conversion factors 2019 to 2023 (Department for Energy Security & Net Zero – UK GOV).

Emission factors provided by the electricity suppliers are used for the calculation of market-based Scope 2 GHG Emissions, when available. Otherwise, the following sources described in the below table are used:

APPENDIX 03

GHG emissions methodology and details

Electricity emission factor sources for scope 2 location-based and scope 2 market-based GHG emissions calculations:

COUNTRY	ELECTRICITY EMISSION FACTOR SOURCES (LOCATION-BASED)	ELECTRICITY EMISSION FACTOR SOURCES (MARKET-BASED)
Belgium, Czech Republic, Spain, France, Italy, Netherlands, Portugal, Poland	European Production Mix Reports - AIB (Association of Issuing Bodies)	European Residual Mix Reports - AIB (Association of Issuing Bodies)
United Kingdom	Greenhouse gas reporting: conversion factors - Department for Energy Security & Net Zero (UK GOV)	
Brazil	Fatores de Emissão de CO ₂ pela geração de energia elétrica no Sistema Interligado Nacional do Brasil, Inventário Corporativo - Ministério da Ciência, Tecnologia e Inovação	Fatores de Emissão de CO ₂ pela geração de energia elétrica no Sistema Interligado Nacional do Brasil, Inventário Corporativo - Ministério da Ciência, Tecnologia e Inovação
Canada	National Inventory Report (NIR) 1990-2020, Part 3, Annex 13 (published 2022) - Environment and Climate Change Canada	National Inventory Report (NIR) 1990-2020, Part 3, Annex 13 (published 2022) - Environment and Climate Change Canada
Mexico	Factores de Emisión del Sistema Eléctrico Nacional - CRE (Comisión Reguladora de Energía)	Factores de Emisión del Sistema Eléctrico Nacional - CRE (Comisión Reguladora de Energía)
United States	GRID – U.S. Environmental Protection Agency US EPA	eGRID – U.S. Environmental Protection Agency US EPA
Russia, Ukraine, Vietnam	Emissions Factors - International Energy Agency IEA	Emissions Factors - International Energy Agency IEA

Note: For Canada and US, regional emissions factors are used, when specific emission factors provided by the electricity suppliers are not available.

SCOPE 3 GHG EMISSIONS

Logoplaste's Scope 3 GHG emissions are calculated according to the Greenhouse Gas Protocol: Corporate Value Chain (Scope 3) Accounting and Reporting Standard. Carbon dioxide (CO₂) is the predominant gas included in the calculation of Scope 3 emissions, but emissions factors may also include small amounts of methane (CH₄) and nitrous oxide (N₂O).

Majority of emissions factors for Scope 3 are from Greenhouse gas reporting: conversion factors 2019 to 2023 (Department for Energy Security & Net Zero – UK GOV). To calculate GHG emissions associated with raw materials, we used the latest eco-profiles published by Plastics Europe and WARM.

Our GHG inventory for previous years is recalculated if it impacts more than 5% of the overall scope.

APPENDIX 04

HR Metrics details by country

Total number of employees by country and gender

COUNTRY	Female	Male	Total
Belgium		18	18
Brazil	98	292	390
Canada	9	65	74
Czech Republic		11	11
France	3	58	61
Ireland	1	2	3
Italy	1	32	33
Luxembourg		6	6
Mexico	32	106	138
Netherlands	13	89	102
Poland	124	210	334
Portugal	113	303	416
Spain	6	64	70
Ukraine	4	8	12
United Kingdom	24	235	259
United States	171	509	680
Vietnam	50	35	85
Grand Total	649	2043	2692

Total number of employees by country and contract type

COUNTRY	Fixed Term	Permanent	Total
Belgium	2	16	18
Brazil	0	390	390
Canada	0	74	74
Czech Republic	1	10	11
France	4	57	61
Ireland	1	2	3
Italy	1	32	33
Luxembourg	1	5	6
Mexico	3	135	138
Netherlands	25	77	102
Poland	14	320	334
Portugal	7	409	416
Spain	1	69	70
Ukraine	0	12	12
United Kingdom	6	253	259
United States	0	680	680
Vietnam	28	57	85
Grand Total	94	2598	2692

APPENDIX 04

HR Metrics details by country

Turnover by country

COUNTRY	Number of Leavers	Average EE's	Turnover %
Belgium	2	16.9	11.8%
Brazil	86	389.4	22.1%
Canada	13	72.7	17.9%
Czech Republic	1	11.0	9.1%
France	25	68.6	36.5%
Ireland	1	3.8	26.1%
Italy	2	33.6	6.0%
Luxembourg	1	5.8	17.4%
Mexico	28	138.7	20.2%
Netherlands	26	97.6	26.6%
Poland	55	321.9	17.1%
Portugal	48	404.0	11.9%
Spain	1	69.8	1.4%
Ukraine	74	255.7	28.9%
United Kingdom	4	14.3	27.9%
United States	314	666.1	47.1%
Vietnam	33	87.1	37.9%
Grand Total	714	2656.9	26.9%

New Hires by country

COUNTRY	Number of New Hires	Average EE's	Ratio New Hires %
Belgium	5	16.9	29.6%
Brazil	81	389.4	20.8%
Canada	14	72.7	19.3%
Czech Republic	1	11.0	9.1%
France	11	68.6	16.0%
Ireland	0	3.8	0.0%
Italy	1	33.6	3.0%
Luxembourg	1	5.8	17.4%
Mexico	35	138.7	25.2%
Netherlands	33	97.6	33.8%
Poland	79	321.9	24.5%
Portugal	77	404.0	19.1%
Spain	4	69.8	5.7%
Ukraine	86	255.7	33.6%
United Kingdom	0	14.3	0.0%
United States	364	666.1	54.6%
Vietnam	14	87.1	16.1%
Grand Total	806	2 656.9	30.3%

APPENDIX 04

HR Metrics details by country

Training hours by Country

COUNTRY	Internal (h)	External (h)	Total (h)
Belgium	0	37	37
Brazil	14 799	9 623	24 422
Canada	4 853	297	5 150
Czech Republic	0	95	95
France	15	72	87
Ireland	0	0	0
Italy	0	325	325
Luxembourg	0	0	0
Mexico	1 644	1 639	3 283
Netherlands	511	40	551
Poland	1 909	851	2 760
Portugal	110	740	2 519
Spain		122	122
Ukraine	2 054	1 139	3 193
United Kingdom	266	361	626
United States	16 192	18	16 209
Vietnam	0	888	888
Grand Total	42 352,8	16 244,7	58 597
	72.3%	27.7%	

Completion of Achieve by Country

COUNTRY	Number EE's with Achieve	Headcount	Ratio EE's with Achieve
Belgium	16	18	88.9%
Brazil	365	390	93.6%
Canada	66	74	89.2%
Czech Republic	10	11	90.9%
France	56	61	91.8%
Ireland	3	3	100.0%
Italy	33	33	100.0%
Luxembourg	6	6	100.0%
Mexico	3	138	2.2%
Netherlands	84	102	82.4%
Poland	115	334	34.4%
Portugal	298	416	71.6%
Spain	28	70	40.0%
Ukraine	11	12	91.7%
United Kingdom	229	259	88.4%
United States	568	680	83.5%
Vietnam	1	85	1.2%
Grand Total	1 892	2 692	70.3%



APPENDIX 05

**Independent Limited
Assurance Report**



Independent Limited Assurance Report

To the Board of Directors

Introduction

We were engaged by the Board of Directors of Logoplaste Group S.A.R.L (“Logoplaste” or “Company”) to perform a limited assurance engagement on the Carbon Footprint scope 1, 2 and 3 that are part of the sustainability information included in the Sustainability Report 2023, for the period ended December 31, 2023, prepared by the Company for the purpose of communicating its annual sustainability performance.

Responsibilities of the Board of Directors

It is the responsibility of the Board of Directors to prepare the Carbon Footprint scope 1, 2 and 3, included in the Sustainability Report 2023, in accordance with the sustainability reporting guidelines “Global Reporting Initiative” (“GRI”) and with the instructions and criteria disclosed in the Sustainability Report 2023, as well as to maintain an appropriate system of internal control that enables the adequate preparation of the mentioned information.

Responsibilities of the auditor

Our responsibility is to issue a limited assurance report, which is professional and independent, based on the procedures performed and specified in the paragraph below.

Our work was conducted in accordance with International Standard on Assurance Engagements (ISAE) 3000 (Revised) “Assurance engagements other than audits or reviews of historical financial information”, issued by the International Auditing and Assurance Standards Board of the International Federation of Accountants and we have fulfilled other technical standards and recommendations issued by the Institute of Statutory Auditors. These standards require that we plan and perform our work to obtain limited assurance about whether the Carbon Footprint scope 1, 2 and 3 included in the Sustainability Report 2023, for the period ended December 31, 2023 is free from material misstatements.

For this purpose the above mentioned work included:

- i) Inquiries to management and senior officials responsible for areas under analysis, with the purpose of understanding how the information system is structured and their awareness of issues included in the report;
- ii) Identification of the existence of internal management procedures leading to the implementation of economic, environmental and social policies;
- iii) Testing, on a sampling basis, the efficiency of processes and systems in place for collection, consolidation, validation and reporting of the performance information analysed, through calculations and validation of reported data;
- iv) Confirmation that operational units follow the instructions on collection, consolidation, validation and reporting of performance information;
- v) Execution of substantive procedures, on a sampling basis, in order to collect evidence of the reported information;

PricewaterhouseCoopers & Associados – Sociedade de Revisores Oficiais de Contas, Lda.
Sede: Palácio Sottomayor, Rua Sousa Martins, 1 - 3º, 1069-316 Lisboa, Portugal
Recepção: Palácio Sottomayor, Avenida Fontes Pereira de Melo, nº16, 1050-121 Lisboa, Portugal
Tel: +351 213 599 000, Fax: +351 213 599 999, www.pwc.pt
Matriculada na CRC sob o NIPC 506 628 752, Capital Social Euros 314.000
Inscrita na lista das Sociedades de Revisores Oficiais de Contas sob o nº 183 e na CMVM sob o nº 20161485

PricewaterhouseCoopers & Associados – Sociedade de Revisores Oficiais de Contas, Lda. pertence à rede de entidades que são membros da PricewaterhouseCoopers International Limited, cada uma das quais é uma entidade legal autónoma e independente.

- vi) Comparison of financial and economic data included in the sustainability information with the data audited by the financial auditor, in the scope of the statutory audit of the Company's consolidated financial statements for the year ended December 31, 2023;
- vii) Verification that the sustainability information (Carbon Footprint scope 1, 2 and 3) included in the Sustainability Report 2023 complies with the requirements of GRI Standards.

The procedures performed were more limited than those used in an engagement to obtain reasonable assurance and, therefore, less assurance was obtained than in a reasonable assurance engagement.

We believe that the procedures performed provide an acceptable basis for our conclusion.

Quality management and independence

We apply the International Standard on Quality Management 1 (ISQM1), which requires that we design, implement and operate a system of quality management including policies or procedures regarding compliance with ethical requirements, professional standards and applicable legal and regulatory requirements.

We have complied with the independence and other ethical requirements of the International Code of Ethics for Professional Accountants (including International Independence Standards) issued by the International Ethics Standards Board for Accountants (IESBA Code) and of the ethics code of the Institute of Statutory Auditors.

Conclusion

Based on the work performed, nothing has come to our attention that causes us to believe that the Carbon Footprint scope 1, 2 and 3, included in the Sustainability Report 2023, for the period ended December 31, 2023, were not prepared, in all material respects, in accordance with GRI Standards requirements and with the instructions and criteria disclosed in the Sustainability Report 2023 and that Logoplaste has not applied, in the sustainability information included in the Sustainability Report, the GRI Standards guidelines and the instructions and criteria disclosed in the Sustainability Report 2023.

Restriction on use

This report is issued solely for information and use of the Board of Directors of the Company for the purpose of communicating its annual sustainability performance in the Sustainability Report 2023 and should not be used for any other purpose. We will not assume any responsibility to third parties other than Logoplaste by our work and the conclusions expressed in this report, which will be attached to the Company's Sustainability Report 2023.

July 30, 2024

PricewaterhouseCoopers & Associados
- Sociedade de Revisores Oficiais de Contas, Lda.
represented by:

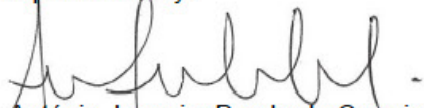

António Joaquim Brochado Correia, ROC no. 1076
Registered with the Portuguese Securities Market Commission under no. 20160688

